

说明

感谢您使用我公司生产的产品。

本零件图册适用于我公司生产的4-4.5吨第三代内燃平衡重式叉车，以便用户在修理更换叉车零部件时，从中查找出所需的零件名称、结构及安装位置，并作为订货参考。

在订货时，必须说明原叉车的型号及出厂日期，并根据本图册，说明零件的详细名称、标号、数量及完整的代号。

我公司叉车根据用户和生产发展，将不断地进行改进，故图册内容可能在一定的时期将有更新，待再版时予以修改，敬请用户注意。

本图册不可避免的存在缺点，我们热诚欢迎用户提出宝贵意见。

本图册由技术中心标准化组编制，第1版，第0次修改。

2014年11月

Introduction

Thank you for selecting our products.

This parts manual is applied for the 4-4.5T the third generation internal counterbalanced forklift produced by our plant. It is convenient for users to identify the description, the structure and the assembling location of the parts replaced or repaired, and to put order on them.

When ordering parts, it is necessary to state the model and the date of manufacture of the forklift, and according to the parts manual, give the description, specification, quantity and code about the part you ordered. Owing to users and our improvement of product, our products will be changed continuously, the information contained in this book may be changed without notice.

For improving our work, customers are sincerely requested to give us comments and suggestions.

The parts manual prepared by the Standardization group of The Technical Center ,VER 1 , REV 0 .

Nov., 2014

查询方法:

- 1.在目录中找到相应的系统或总成;
- 2.翻至所标页数,找到该图;
- 3.在其图中找出所需零部件,以及它所标注的序号;
- 4.根据这个序号,在其后附表中可以查到系统或零件的详细信息.

订购零部件时,务请写清叉车的型号,出厂编号,所需零部件的图号及订购数量.维修时,请使用原厂家提供的零部件,以确保叉车质量.

Indexing Way:

- 1.Find out the system or assembly from the indexing.
- 2.Turn to above page, find out the drawing.
- 3.Find out the part you require and its item number from the drawing.
- 4.According to the item number, find out detailed information about the system or assembly from the attached table.

When ordering parts, please indicate the model and serial number of forklift, and the chart number and quantity of parts you require..

When replacing the forklift, please original parts of our company to ensure the quality of truck.

目录/Contents

发动机总成/Engine assembly	1
空滤器总成/Air cleaner assembly	2
散热器总成/Radiator assembly	3
燃油装置总成/Fuel device assembly	4
消声器总成/Muffler assembly	6
传动系统/Drive system	8
驱动轮总成/Tire assembly	10
转向操纵总成/Steering control assembly	11
转向桥总成/Steering axle assembly	13
油门操纵总成/Throttle control assembly	14
熄火操纵系统/Flameout control system	16
行车制动总成/Service brake assembly	17
停车制动系统/Parking brake system	19
车架/Frame	20
覆盖件总成/Mantle assembly	21
门架(基本型)/Mast (normal mast)	23
货叉及货叉架/Fork & fork carrier	26
起升油缸(基本型)/Lift cylinder (normal mast)	28
倾斜油缸总成/Tilt cylinder assembly	31
门架侧移管路(基本型)/Side shifting pipe mast(normal mast)	33
门架起升管路(基本型)/Lift pipe mast(normal mast)	35
多路阀操纵/Multi-way valve control	37
液压系统/Hydraulic system	39

目录/Contents

液压油箱盖板总成/Hydraulic oil tank cover plate	42
护顶架/Overhead guard	44
电气系统/Electric system	46
护顶架线束总成/Overhead guard harness assembly	48
蓄电池总成/Battery assembly	49
标牌/Label	51
平衡重/Counter weight	53

发动机总成/Engine assembly

通用

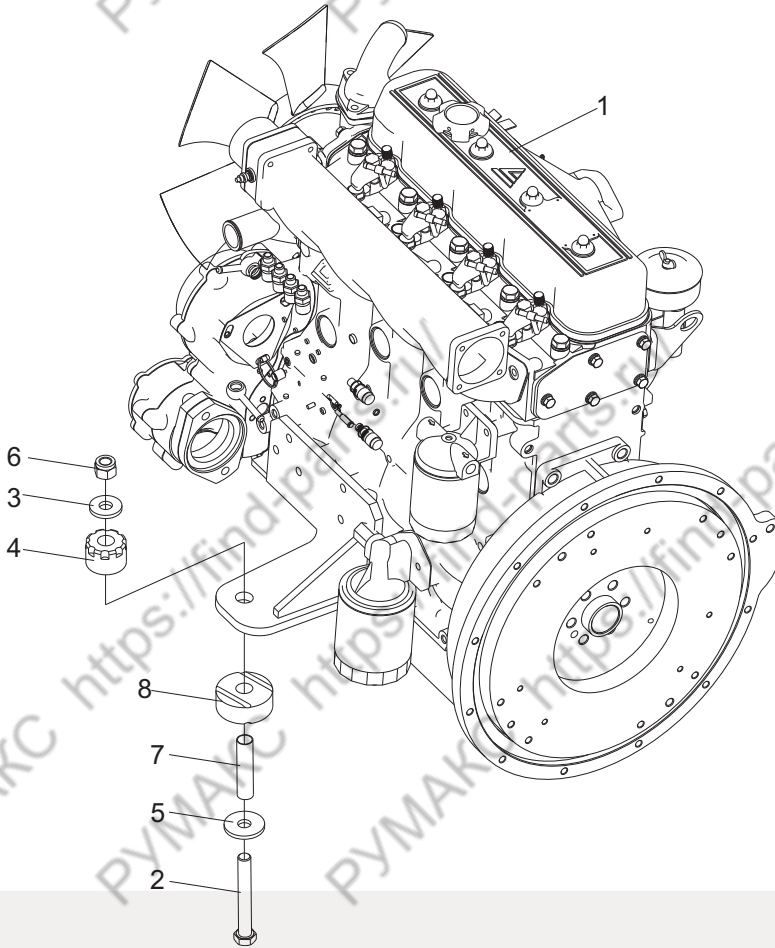

序号 Item No	编 码 Code	图 号 Part No	零部件名称 Description	数量 Q'ty	备 注 Remark
1	30001012077	LG0045DXAIII.01.05.01	发动机总成 Engine assembly	1	
2	51203132814	GB/T5782	螺栓M16X120 Bolt M16×120	2	
3	30002106403	LG0045DXAIII.02.03-001	垫圈 Washer	2	
4	30002109000	LG0045DXAIII.02.03-002	减震垫 Rubber gasket	2	
5	30002106404	LG0045DXAIII.02.03-005	垫圈 Washer	2	
6	51341000919	GB/T889.1	螺母M16 Nut M16	2	
7	30002107401	LG0045DXAIII.02.03-004	钢管 Sleeve	2	
8	30002109001	LG0045DXAIII.02.03-003	减震垫 Rubber gasket	2	

空滤器总成 / Air cleaner assembly

通用

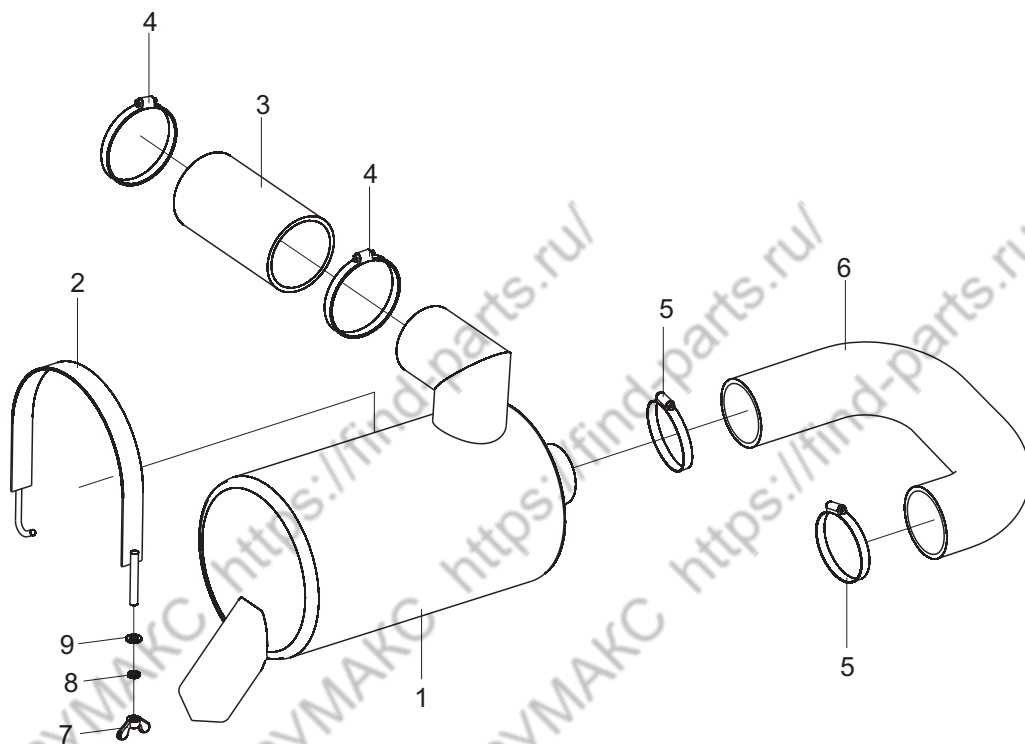

序号 Item No	编 码 Code	图 号 Part No	零 部 件 名 称 Description	数量 Q'ty	备 注 Remark
1	30001014867	LG0045DXAIII.01.01.01	空滤器总成 Air cleaner assembly	1	
2	30001010205	LG0045DXAIII.01.01.02	U型卡总成 U-clamp assembly	1	
3	30001106112	LG0045DXAIII.01.01-001	成型管 Molding pipe	1	
4	56171002801	JB/T8870	喉箍d100(80~100) Hoop d100(80~100)	2	
5	56171002201	JB/T8870	喉箍d80(60~80) Hoop d80(60~80)	2	
6	30001106013	LG0045DXAIII.01.01-002	成型管 Molding pipe	1	
7	51354001804	GB/T62.1	螺母M8 Nut M8	1	
8	51401090107	GB/T93	垫圈8 Washer 8	1	
9	51421090115	GB/T97.1	垫圈8 Washer 8	1	

散热器总成/Radiator assembly

通用

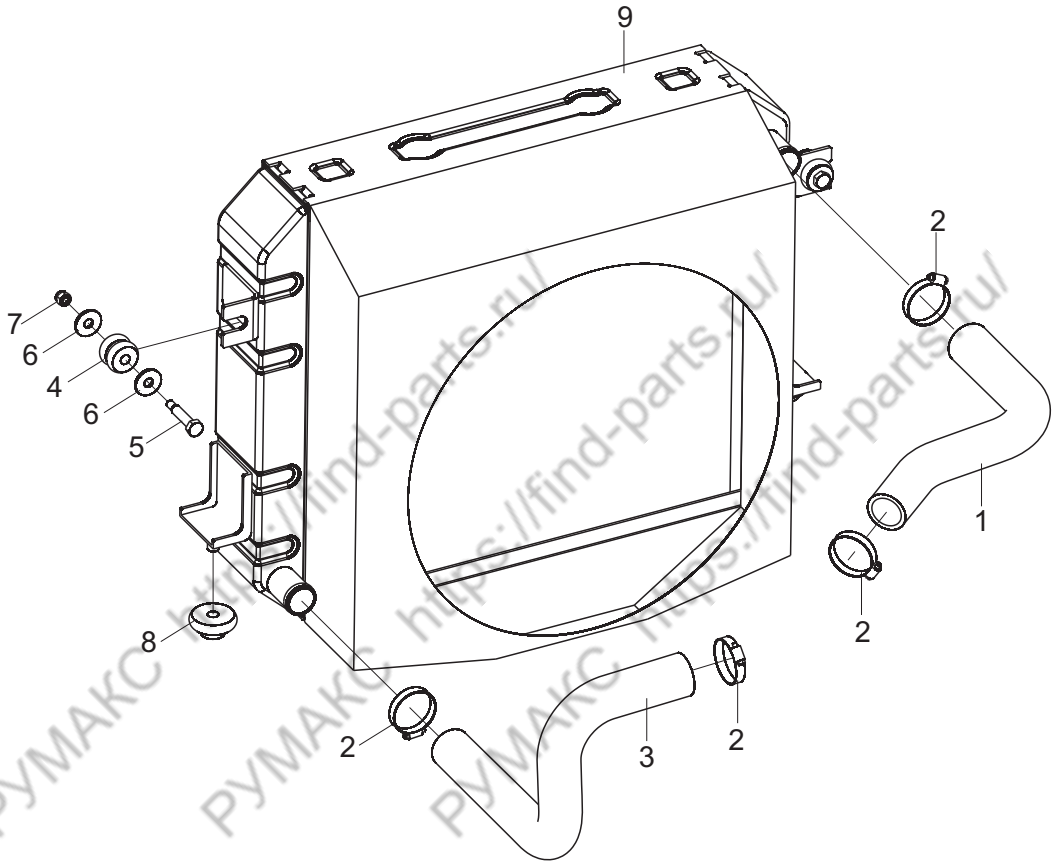

序号 Item No	编 码 Code	图 号 Part No	零部件名称 Description	数量 Q'ty	备 注 Remark
1	30001106113	LG0045DXAIII.01.02-001	成型管 Molding pipe	1	
2	56171002701	JB/T8870	喉箍d60 (40~60) Hoop d60(40~60)	4	
3	30001106130	LG0045DXAIII.01.02-002	成型管 Molding pipe	1	
4	30001109000	30D-0121003	减震垫 Rubber gasket	2	
5	60911011061	30D-0141004	六角螺栓 Bolt	2	
6	51420100121	GB/T96.1	垫圈10 Washer 10	4	
7	51341000519	GB/T889.1	螺母M8 Nut M8	2	
8	30001109001	30D-0121004	减震垫 Rubber gasket	2	
9	17101000420	LG0045DXAIII.01.02.01	散热器总成 Radiator assembly	1	

燃油装置总成 / Fuel device assembly

通用

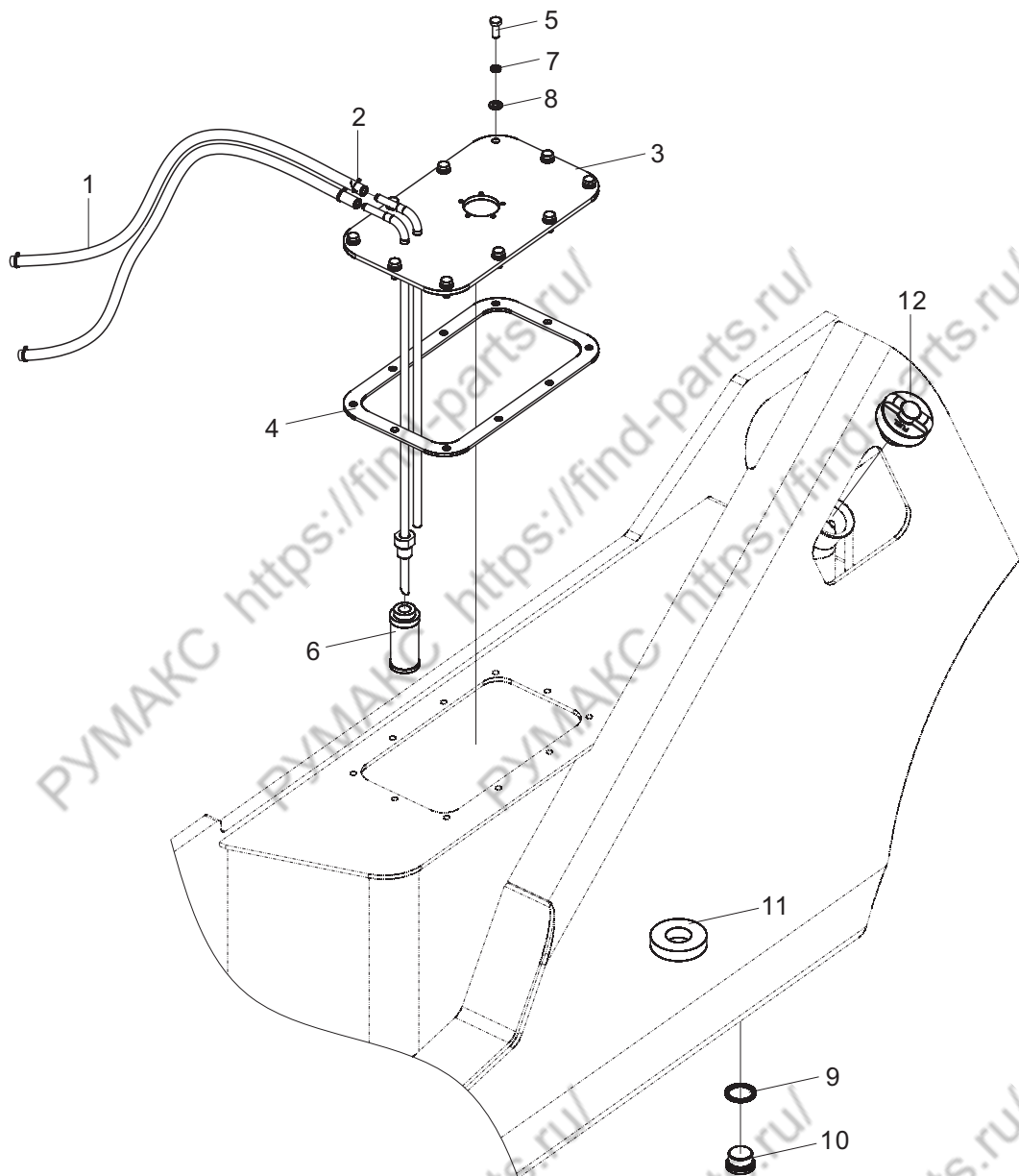

燃油装置总成/Fuel device assembly

序号 Item No	编 码 Code	图 号 Part No	零 部 件 名 称 Description	数 量 Q'ty	备 注 Remark
1	30001109210	LG0045DT.01.05-001	胶管 Hose	2	
2	56171000101	JB/T8870	喉箍d16(10~16) Hoop d16(10~16)	4	
3	30001015917	LG0045DXAIII.01.04.01	燃油箱盖板焊合 Fuel tank cover plate weldment	1	
4	30001111505	LG0045DT.01.05-002	密封垫 Seal gasket	1	
5	51204091014	GB/T5783	螺栓M8X20 Bolt M8×20	10	
6	30001015100	LG0030D.01.03.03	滤芯总成 Filter element assembly	1	
7	51401090107	GB/T93	垫圈8 Washer 8	10	
8	51421090115	GB/T97.1	垫圈8 Washer 8	10	
9	56147011701	JB/T982	组合垫圈30 Combination washer 30	1	
10	56302001202	JB/ZQ4444	螺塞M30X1.5 Plug M30×1.5	1	
11	30008154200	LG0060DT.08-003	磁铁70X32X15 Magnet 70×32×15	1	
12	60980000847	LG0060DT.08-008	加油口盖 Oil filler cap	1	

消声器总成/Muffler assembly

通用

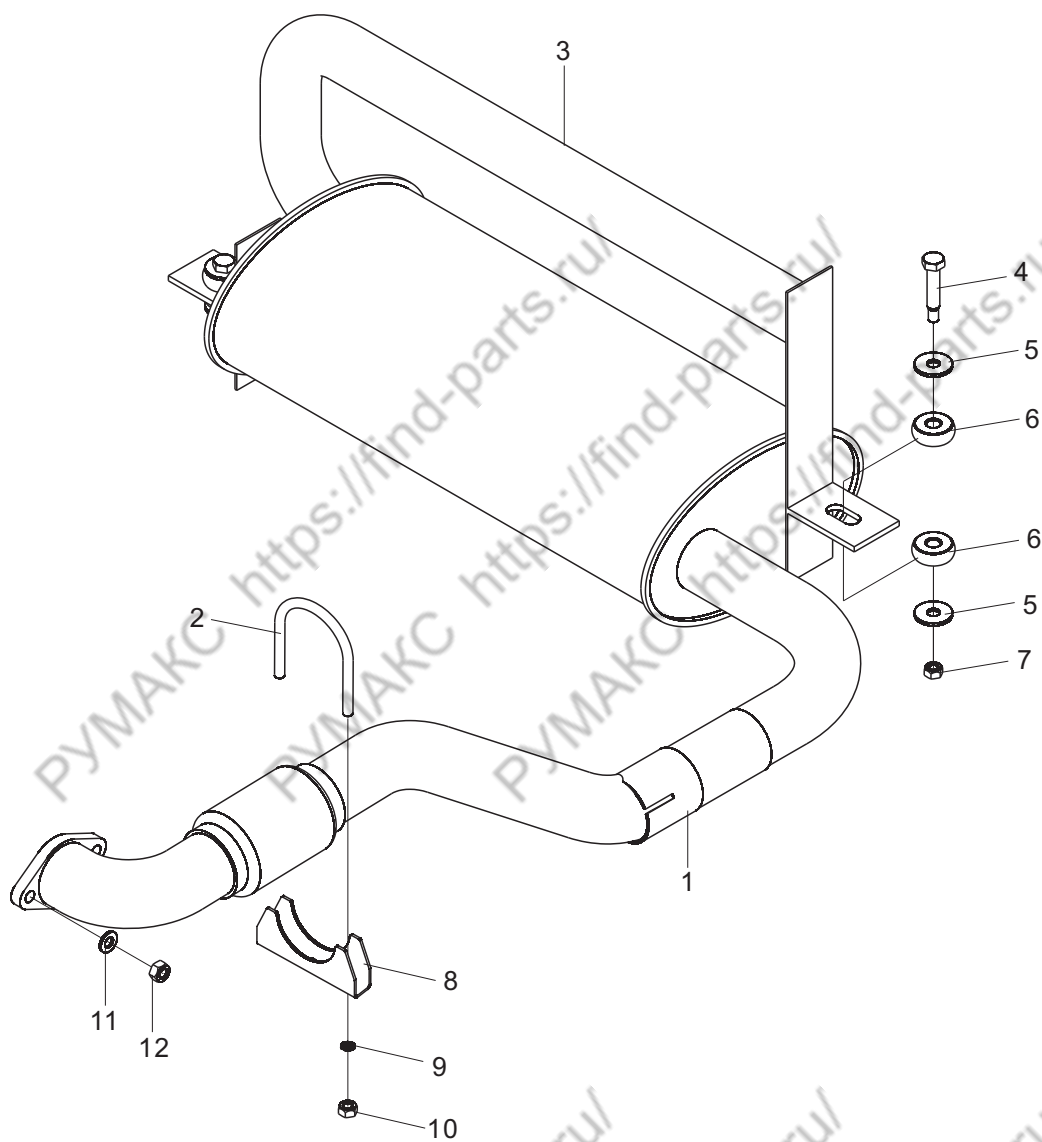

传动系统/Drive system

通用

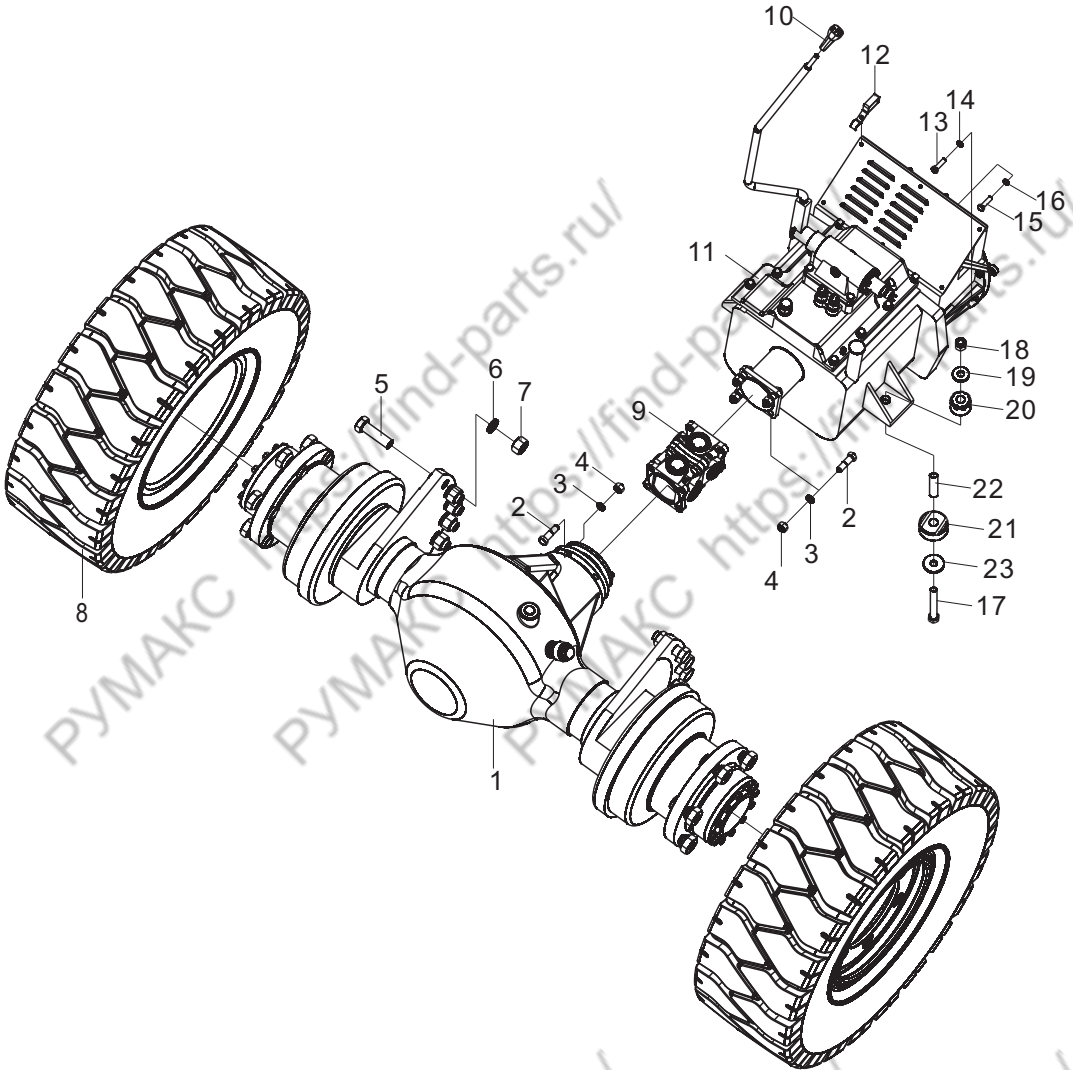

传动系统/Drive system

序号 Item No	编 码 Code	图 号 Part No	零部件名称 Description	数量 Q'ty	备 注 Remark
1	30002024556	LG0045DXAIII.02.01.01	驱动桥总成 Drive axle assembly	1	
2	51210120215	GB/T5785	螺栓M14X1.5X50 Bolt M14×1.5×50	8	
3	51401120107	GB/T93	垫圈14 Washer 14	8	
4	51349000621	GB/T6185.2	螺母M14X1.5 Nut M14×1.5	8	
5	51207172218	GB/T5786	螺栓M24X2X80 Bolt M24×2×80	10	
6	51401170107	GB/T93	垫圈24 Washer 24	10	
7	51309001220	GB/T6171	螺母M24X2 Nut M24×2	10	
8	30002024305	LG0045DT.02.01	驱动轮总成 Drive wheel assembly	2	
9	17408000036	LG0045DXAIII.02.02	传动轴总成 Propeller shaft assembly	1	
10	30002132004	LG0045DXAIII.02.03-006	手柄 Knob	1	
11	30002020361	LG0045DXAIII.02.03.01	变速箱总成 Transmission assembly	1	
12	30002107800	LG0030D.02-002	管夹 Clip	2	
13	51204101314	GB/T5783	螺栓M10X35 Bolt M10×35	10	
14	51401100107	GB/T93	垫圈10 Washer 10	10	
15	51204091214	GB/T5783	螺栓M8X30 Bolt M8×30	12	
16	51401090107	GB/T93	垫圈8 Washer 8	12	
17	51203132814	GB/T5782	螺栓M16X120 Bolt M6×120	2	
18	51341000919	GB/T889.1	螺母M16 Nut M6	2	
19	30002106403	LG0045DXAIII.02.03-001	垫圈 Washer	1	
20	30002109000	LG0045DXAIII.02.03-002	减震垫 Rubber gasket	1	
21	30002109001	LG0045DXAIII.02.03-003	减震垫 Rubber gasket	1	
22	30002107401	LG0045DXAIII.02.03-004	套管 Sleeve	1	
23	30002106404	LG0045DXAIII.02.03-005	垫圈 Washer	1	

驱动轮总成/Tire assembly

通用

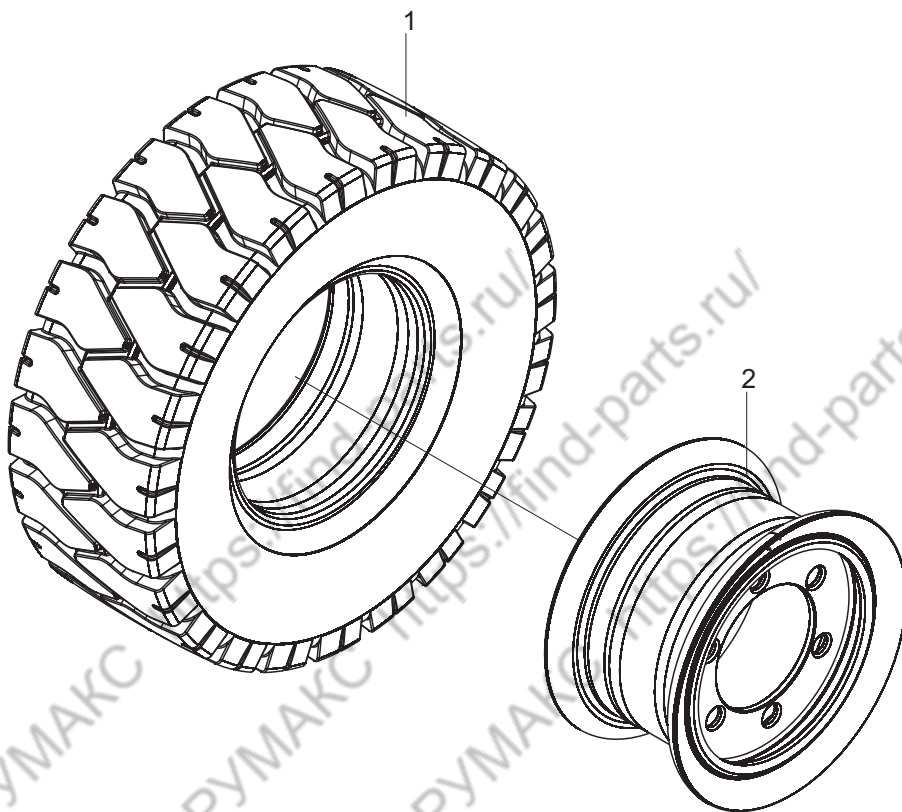

序号 Item No	编 码 Code	图 号 Part No	零 部 件 名 称 Description	数 量 Q'ty	备 注 Remark
1	60205000187	LG0045DT.02.01-001	轮胎总成300-15-18PR Tire assembly	2	
2	60205000188	LG0045DT.02.01-002	轮辋焊合8.00V-15 Rim Weldment	2	

转向操纵总成/Steering control assembly

通用

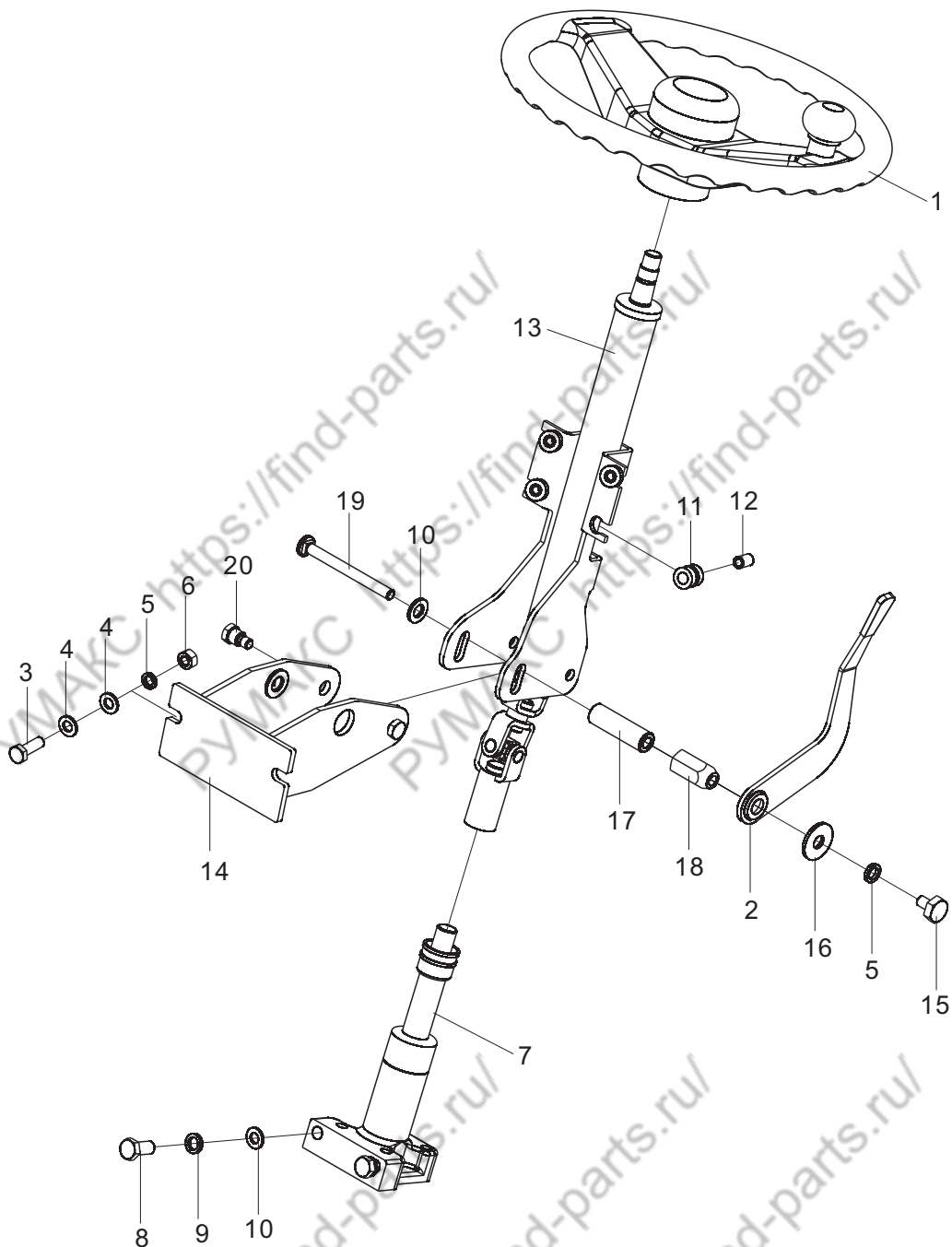

转向桥总成/Steering axle assembly

通用

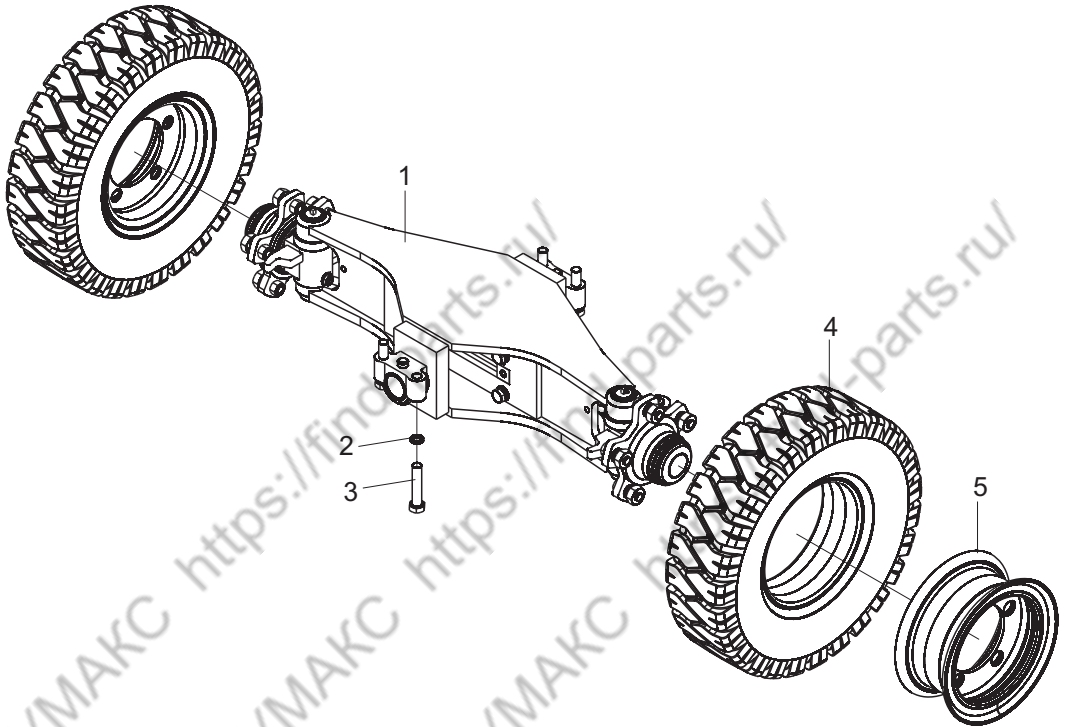

序号 Item No	编 码 Code	图 号 Part No	零部件名称 Description	数量 Q'ty	备 注 Remark
1	30003035316	LG0045DT.03.02	转向桥总成 Steering axle assembly	1	
2	51401150107	GB/T93	垫圈20 Washer 20	4	
3	51210152414	GB/T5785	螺栓M20X1.5X90 Bolt M20×1.5×90	4	
4	60205000175	LG0025D.02.01.02.01	轮胎7.00-12-12PR Tire 7.00-12-12PR	2	
5	60205000150	LG0045DT.03.03.01	轮辋总成5.00S-12 Rim assembly 5.00S-12	2	

油门操纵总成/Throttle control assembly

通用

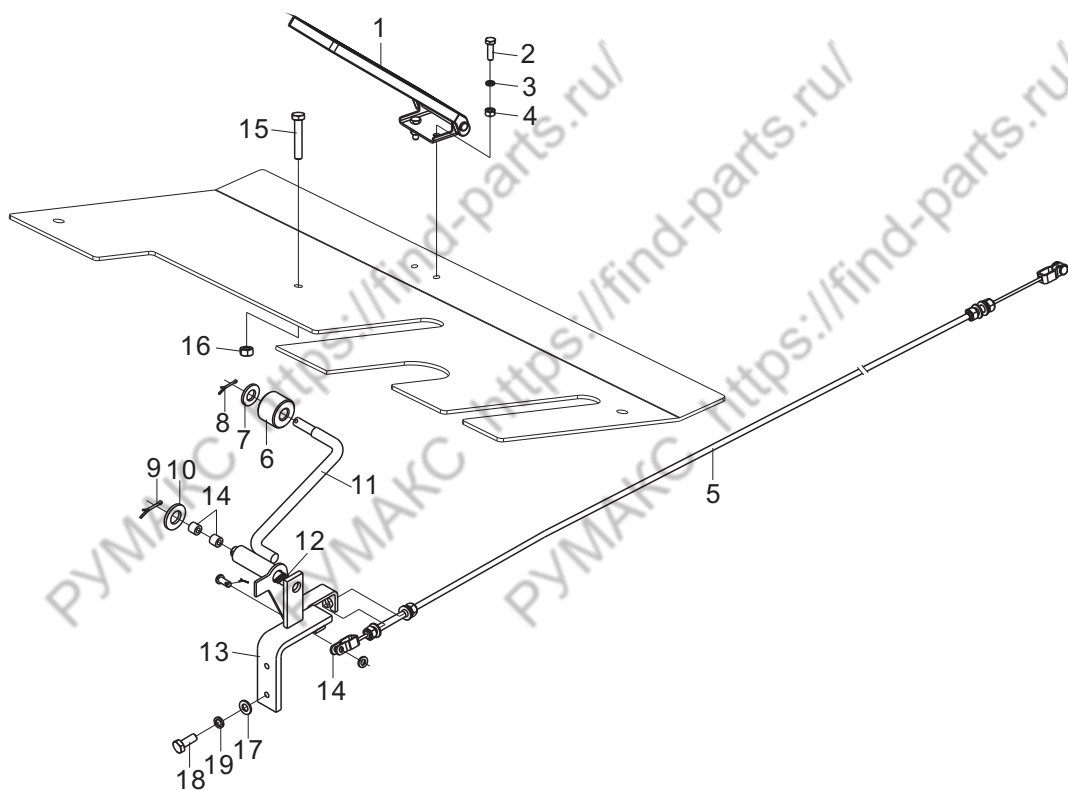

熄火操纵系统/Flameout control system

通用



序号 Item No	编 码 Code	图 号 Part No	零 部 件 名 称 Description	数 量 Q'ty	备 注 Remark
1	30005040404	LG0045DXAIII.05.01	拉索总成 Cable assembly	1	

行车制动总成/Service brake assembly

通用

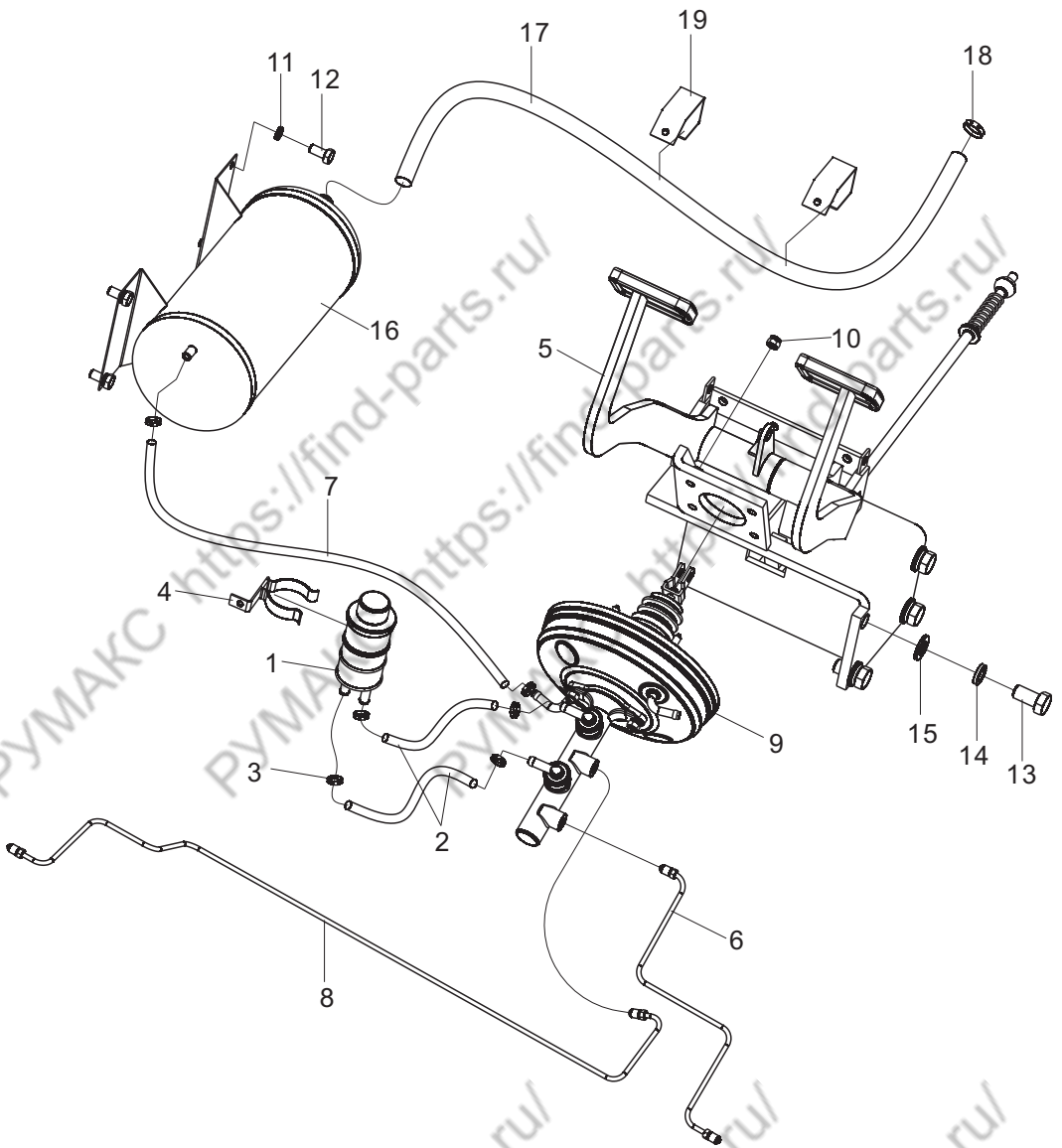

停车制动系统/Parking brake system

通用

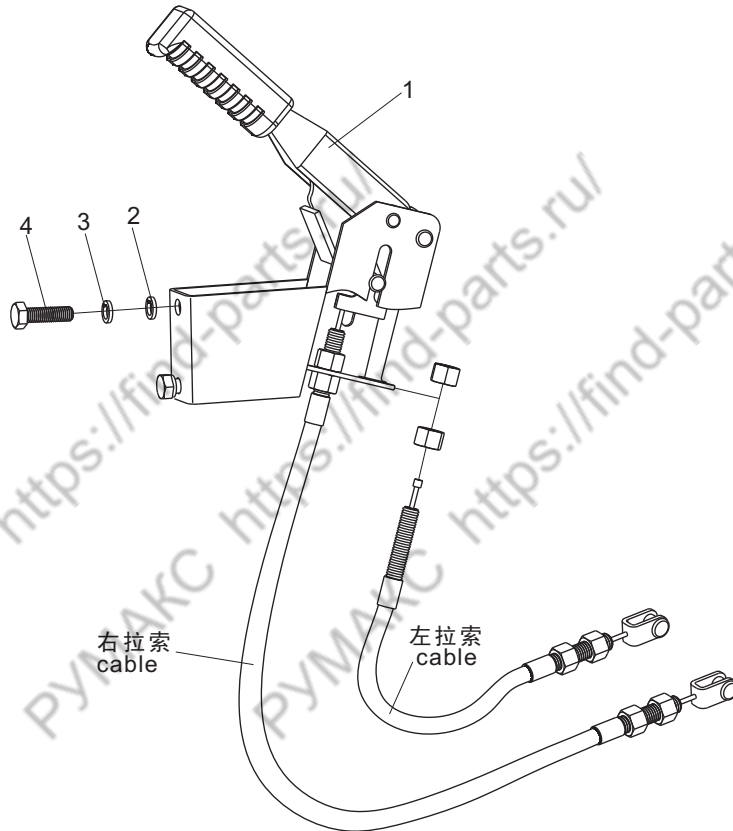

序号 Item No	编 码 Code	图 号 Part No	零部件名称 Description	数量 Q'ty	备 注 Remark
1	60208000088	LG0030D.07.01	手制动手柄总成 Parking brake handle	1	
2	51421100115	GB/T97.1	垫圈10 Washer 10	2	
3	51401100107	GB/T93	垫圈10 Washer 10	2	
4	51204101114	GB/T5783	螺栓M10X25 Bolt M10×25	2	

车架/Frame

通用

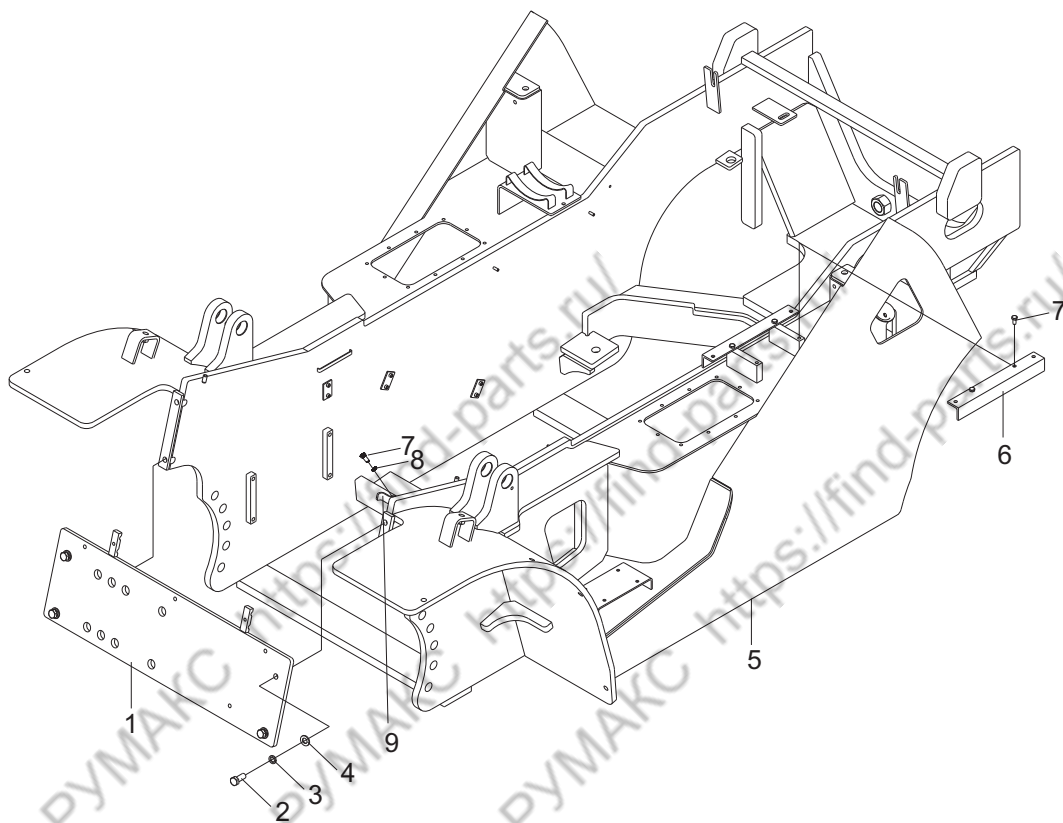

序号 Item No	编 码 Code	图 号 Part No	零 部 件 名 称 Description	数量 Q'ty	备 注 Remark
1	30008047119	LG0045DXAIII.08.01	连接板焊合 Connecting plate weldment	1	
2	51204121314	GB/T5783	螺栓M14X35 Bolt M14×35	4	
3	51401120107	GB/T93	垫圈14 Washer 14	4	
4	51421120115	GB/T97.1	垫圈14 Washer 14	4	
5	30008050041	LG0045DXAIII.08.02	车架焊合 Chassis weldment	1	
6	30008018116	LG0045DXAIII.08.03	支架焊合 Bracket weldment	2	
7	51204090914	GB/T5783	螺栓M8X16 Bolt M8×16	5	
8	51401090107	GB/T93	垫圈8 Washer 8	1	
9	30008113059	LG0045DXAIII.08-001	弯板 Bending plate	1	

覆盖件总成/Mantle assembly

通用

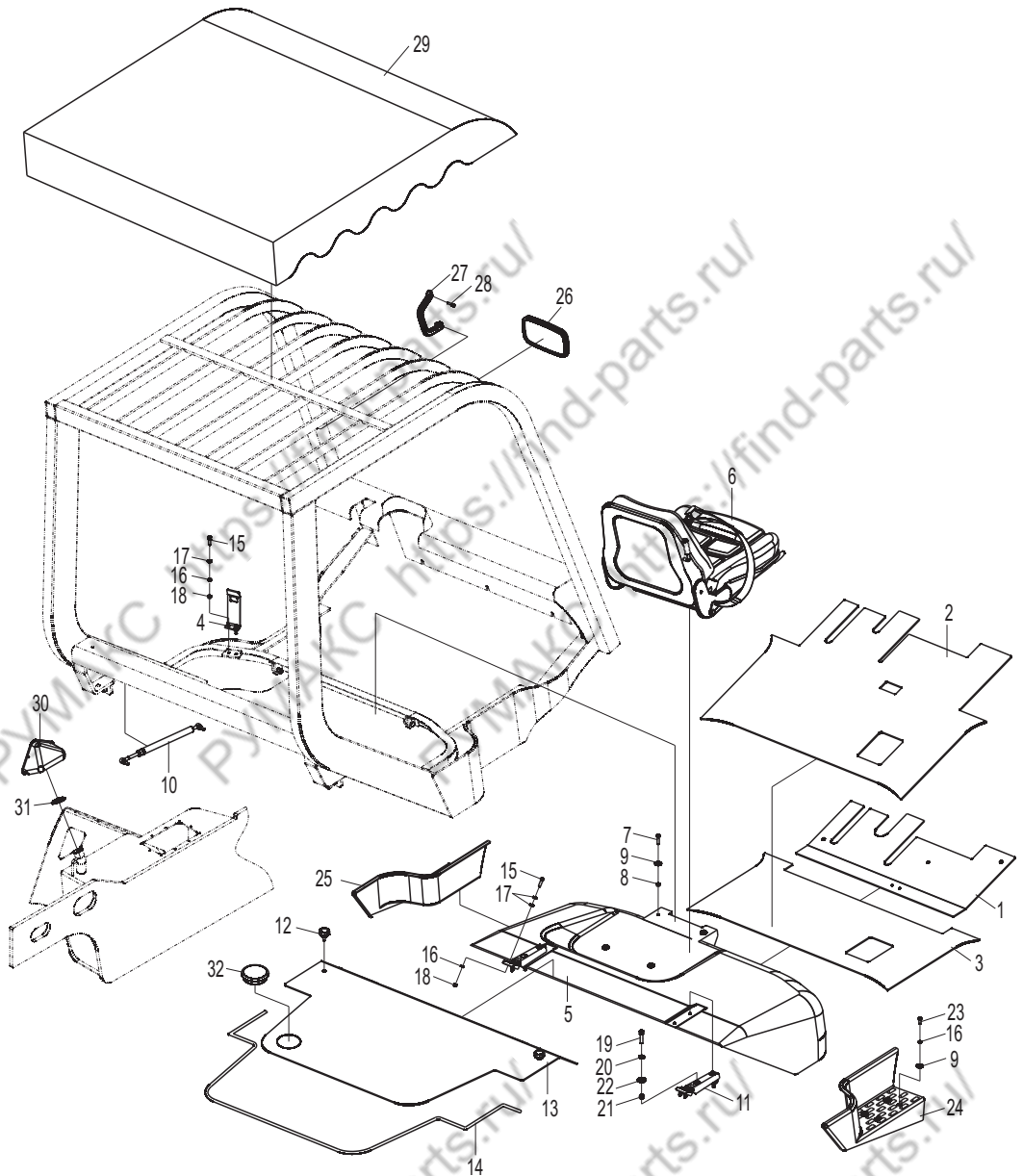

覆盖件总成/Mantle assembly

序号 Item No	编 码 Code	图 号 Part No	零 部 件 名 称 Description	数量 Q'ty	备 注 Remark
1	30009045949	LG0045DXAIII.09.01	底板焊合 Bottom plate weldment	1	
2	30009113917	LG0045DXAIII.09.001	橡胶垫 Rubber gasket	1	
3	30009045950	LG0045DXAIII.09.02	底板焊合 Bottom plate weldment	1	
4	30009113014	LG0045DXAIII.09.002	弯板 Bent plate	1	
5	30009046012	LG0045DXAIII.09.03	发动机罩总成 Engine hood assembly	1	
6	60920011458	LG0030D.09.06	座椅总成 Seat assembly	1	
7	51204091214	GB/T5783	螺栓M8X30 Bolt M8×30	4	
8	51347000319	GB/T6184	螺母M8 Nut M8	4	
9	51420090121	GB/T96.1	垫圈8 Washer 8	12	
10	67206000398	LG0016BE.09.12.02	气弹簧总成 Air spring assembly	1	
11	60701010156	LG0030D.09.08	铰链合件 Hinge element	2	
12	30009157300	20B-0900003	螺钉 Screw	2	
13	30009046509	LG0045DXAIII.09.04	盖板焊合 Cover plate weldment	1	
14	60980004829	LG0045DT.09-003	U形装饰条 U-decoration stripe	1	
15	51139210605	GB/T70.1	螺钉M8X30 Screw M8×30	6	
16	51401090107	GB/T93	垫圈8 Washer 8	14	
17	51421090115	GB/T97.1	垫圈8 Washer 8	10	
18	51307000919	GB/T6170	螺母M8 Nut M8	6	
19	51139220605	GB/T70.1	螺钉M10X40 Screw M10×40	4	
20	51421100115	GB/T97.1	垫圈10 Washer 10	4	
21	51347000419	GB/T6184	螺母M10 Nut M10	4	
22	51420100121	GB/T96.1	垫圈10 Washer 10	4	
23	51204090914	GB/T5783	螺栓M8X16 Bolt M8×16	8	
24	30009146825	LG0045DXAIII.09-004	踏板 Pedal	1	
25	30009146826	LG0045DXAIII.09-005	踏板 Pedal	1	
26	60917010007	30D-0902000	倒车镜 Rearview mirror	1	
27	30009156200	20B-0900001	把手 Handle	1	
28	51139190605	GB/T70.1	螺钉M6X25 Screw M6×25	2	
29	60900000870	LG0045DXAIII.09.05	雨篷 Rain shelter	1	
30	30009108715	LG0045DXAIII.09-006	护罩 Guard	1	
31	30009106400	LG0030DIII.09-006	护圈 Retainer	1	
32	30009158002	LG0060DT.09-007	橡胶盖 Rubber cover	1	

门架(基本型) / Mast (normal mast)

通用

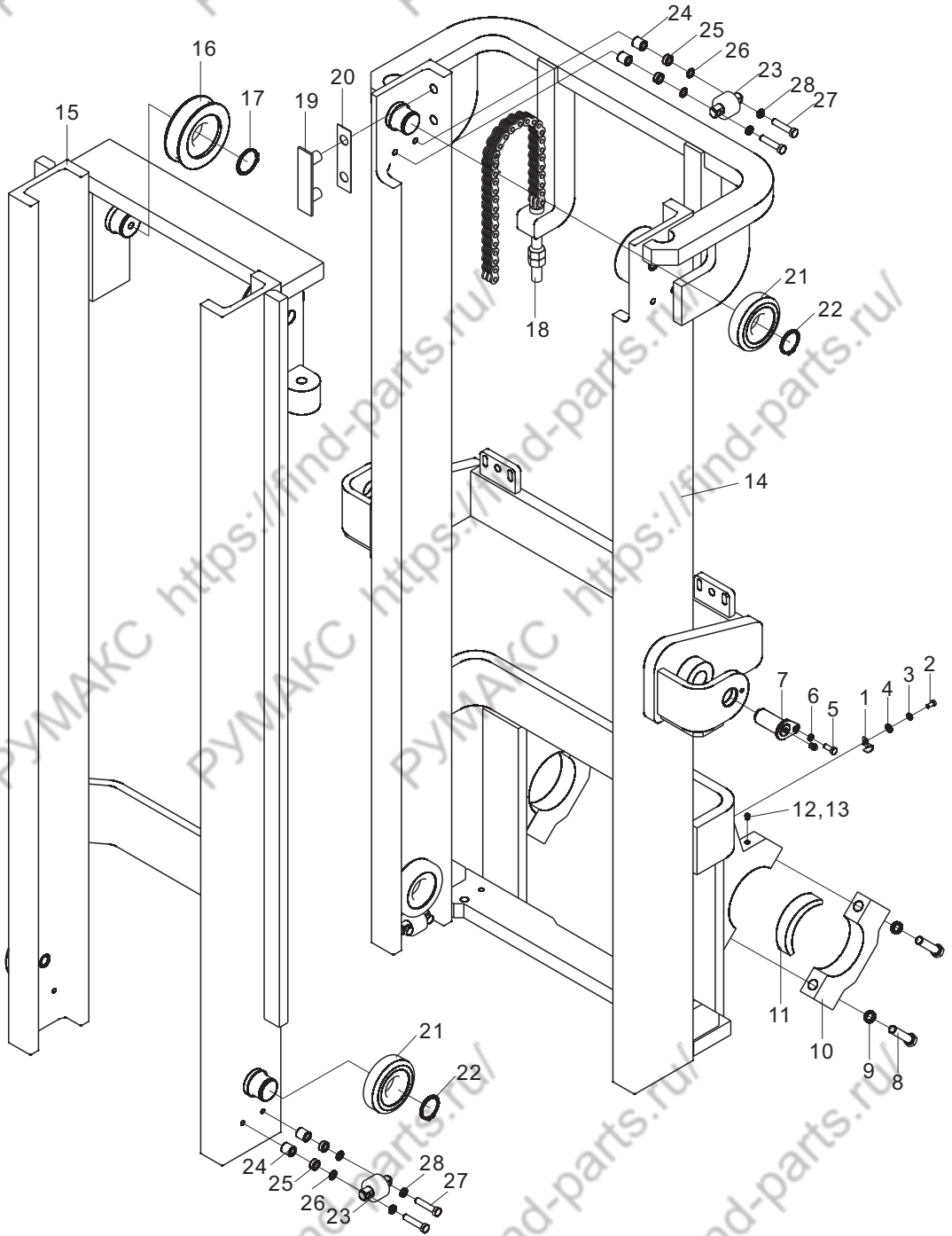

门架(基本型) / Mast (normal mast)

序号 Item No	编 码 Code	图 号 Part No	零部件名称 Description	数量 Q'ty	备 注 Remark
1	30082107800	LG0030D.10-015	管夹 Clip	2	
2	51204091014	GB/T5783	螺栓M8X20 Bolt M8×20	2	
3	51401090107	GB/T93	垫圈8 Washer 8	2	
4	51421090115	GB/T97.1	垫圈8 Washer 8	2	
5	51204101114	GB/T5783	螺栓M10X25 Bolt M10×25	2	
6	51401100107	GB/T93	垫圈10 Washer 10	2	
7	30086025000	LG0045DT.10.05	销轴焊接 Pin shaft weldment	2	
8	51210152714	GB/T5785	螺栓M20X1.5X110 Bolt M20×1.5×110	4	
9	51401150107	GB/T93	垫圈20 Washer 20	4	
10	30008118503	LG0045DT.08-001	端盖 End cover	2	
11	30086184500	LG0045DT.10-005	轴衬 Shaft bushing	2	
12	56201000301	JB/T7940.1	油杯M10X1 Oil cup M10×1	2	
13	60980005823	LG0030D.10-021	红色保护套 Red sheath	2	
14	30086082709	LG0045DXAⅢ.10.01	外门架焊接 Outer master weldment	1	高度3000
15	30086081700	LG0045DXAⅢ.10.02	内门架焊接 Inner mast weldment	1	高度3000
16	30086185700	LG0040D.10-001	链轮 Chain wheel	2	
17	51453420107	GB/T894.1	挡圈55 Snap ring 55	2	
18	30086080416	LG0045D.10.18	链条总成LH1634 Chain assembly	2	85节
19	30082185100	LG0030D.10-007	滑块 Sliding block	2	
20	30082154800	LG0030D.10-008	调整垫 Adjustable gasket	2	0.5mm
	30082154805	LG0030D.10-008	调整垫 Adjustable gasket	2	1.0mm
	30082154806	LG0030D.10-008	调整垫 Adjustable gasket	2	2.0mm
21	30086141005	LG0045D.10.10	滚轮 Roller	4	
22	51453400107	GB/T894.1	挡圈50 Snap ring 50	4	
23	30086141008	LG0045DXAⅢ.10-001	滚轮 Roller	4	
24	30086106401	LG0045D.10-008	垫圈 Washer	8	
25	30086106400	LG0060DT.10.13	垫圈 Washer	8	
26	30086054801	LG0060DT.10-008	调整垫 Adjustable gasket	8	
27	51204111714	GB/T5783	螺栓M12X55 Bolt M12×55	8	
28	51401110107	GB/T93	垫圈12 Washer 12	8	

门架参数/Parameter(mast)

编 码 Code	起升高度 Lifting H	内门架 Inner mast	外门架 Outer mast	链条编码 Code,chain	链条节数 Chain,leaf	备 注 Remark
30086911001	2500	30086081701	30086082710	30086080401	75	
30086911000	3000	30086081700	30086082709	30082080404	85	标准
30086911002	3300	30086081702	30086082711	30086080402	91	
30086911003	3500	30086081703	30086082712	30086080403	95	
30086911004	3750	30086081704	30086082713	30082080407	101	
30086911005	4000	30086081705	30086082636	30086080416	107	
30086911006	4250	30086081706	30086082637	30082080409	111	
30086911007	4500	30086081707	30086082638	30086080413	117	
30086911008	4750	30086081708	30086082639	30082080411	121	
30086911009	5000	30086081709	30086082640	30086080417	127	
30086911010	5500	30086081710	30086082641	30086080408	137	
30086911011	6000	30086081711	30086082642	30086080409	147	

货叉及货叉架/Fork & fork carrier

通用

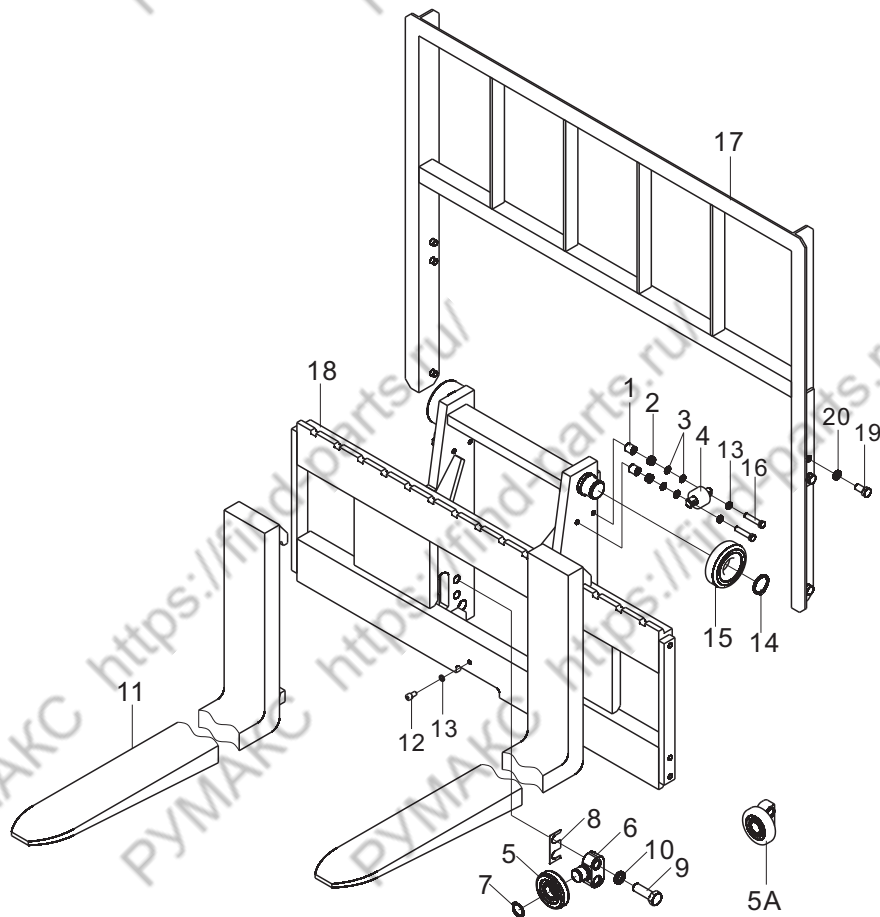

序号 Item No	货叉编码 Code, fork(4.5T)	货叉规格 Model, fork(4.5T)	备注 Remark
1	30086081208	1070×150×55	标准
2	30086081209	1220×150×55	
3	30086081210	1370×150×55	
4	30086081211	1520×150×55	
5	30086081212	1670×150×55	
6	30086081213	1820×150×55	
7	30086081214	1900×150×55	
8	30086081215	2000×150×55	

货叉及货叉架/Fork & fork carrier

序号 Item No	编 码 Code	图 号 Part No	零 部 件 名 称 Description	数 量 Q'ty	备 注 Remark
1	30086106401	LG0045D.10-008	垫圈 Washer	4	
2	30086106400	LG0060DT.10-007	垫圈 Washer	4	
3	30086054801	LG0060DT.10.13	调整垫 Adjustable gasket	4	
4	30086141008	LG0045DXAIII.10-001	滚轮 Roller	2	
5A	30086081400	LG0060DT.10.05	滚轮总成 Roller assembly	2	
5	30086141002	LG0060DT.10.05-001	滚轮 Roller	2	含5-7
6	30086180702	LG0060DT.10.05-002	滚轮轴 Roller shaft	2	
7	51453310107	GB/T894.1	挡圈35 Snap ring 35	2	
8	30086054800	LG0060DT.10.12	调整垫 Adjustable gasket	2	
9	51204161914	GB/T5783	螺栓M22×65 Adjustable gasket	4	
10	51401160107	GB/T93	垫圈22 Washer 22	4	
11	30086081208	LG0045DT.10.10	货叉总成 Fork assembly	2	
12	51139230205	GB/T70.1	螺钉M12×25 Screw M12×25	1	
13	51401110107	GB/T93	垫圈12 Washer 12	5	
14	51453400107	GB/T894.1	挡圈50 Snap ring 50	8	
15	30086141005	LG0045D.10.10	滚轮 Roller	8	
16	51204111714	GB/T5783	螺栓M12×55 Bolt M12×55	4	
17	30086086001	LG0045DXAIII.10.03	挡货架焊合 Load backrest weldment	1	
18	30086081012	LG0045DXAIII.10.04	货叉架焊合 Fork carrier weldment	1	
19	51204134214	GB/T5783	螺栓M16×30 Bolt M16×30	6	
20	51401130107	GB/T93	垫圈16 Washer 16	6	

起升油缸(基本型) / Lift cylinder (normal mast)

通用

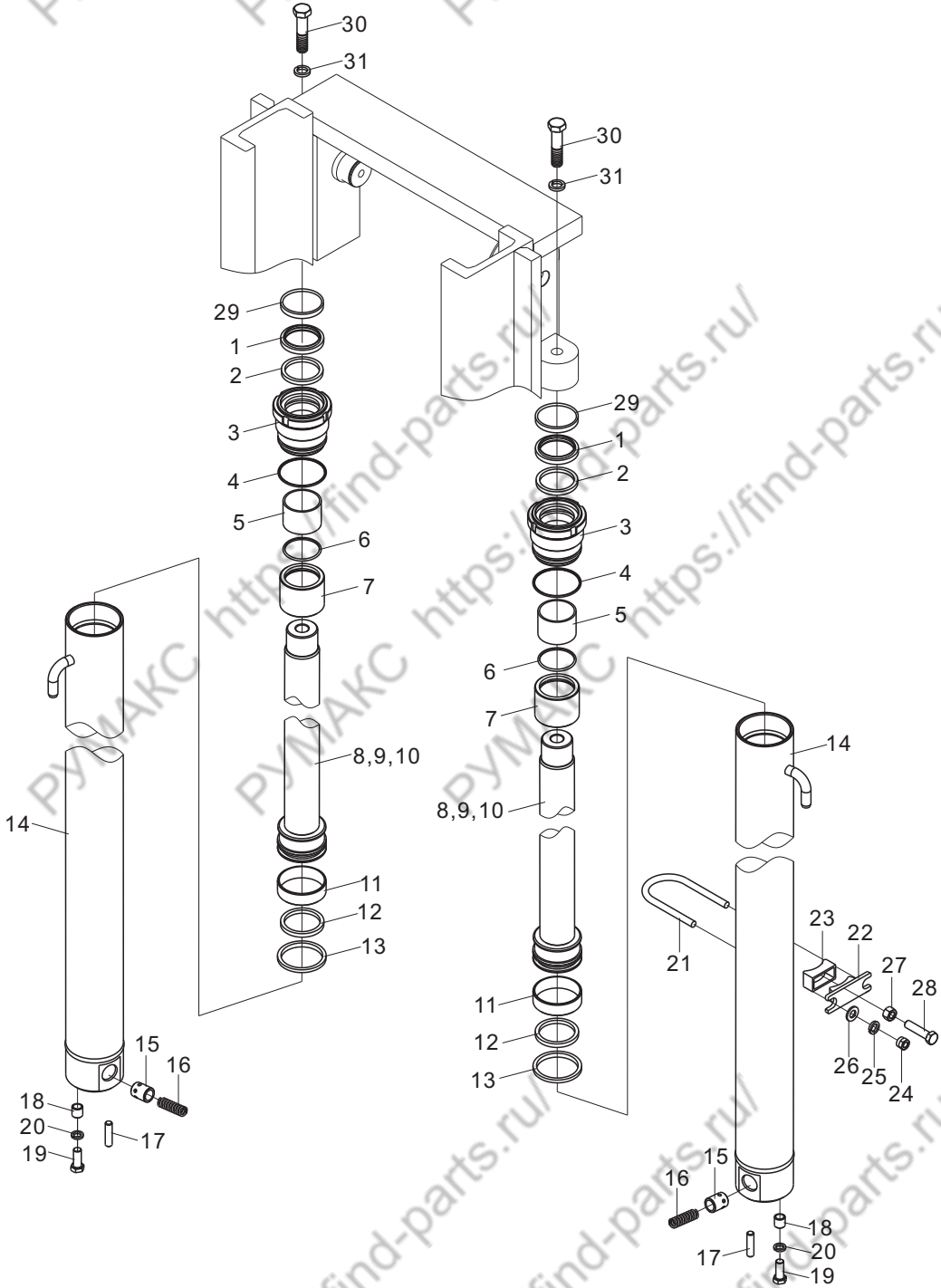

起升油缸(基本型) / Lift cylinder (normal mast)

序号 Item No	编 码 Code	图 号 Part No	零 部 件 名 称 Description	数量 Q'ty	备 注 Remark
A	16600145390	LG0045D.10.17	4. 5T3m起升油缸 Lift cylinder	2	
1	56193000501		防尘圈50X62X7 Dustproof ring 50×62×7	2	
2	56187006601		轴用密封圈50X60X7 Seal ring 50×60×7	2	
3	36600030231	LGG045SP300B-H-01	导向套 Guide sleeve	2	
4	56197000301	JISB2401	O形圈64. 4X3. 1 O-ring 64.4×3.1	2	
5	52500003101		钢背轴承50X55X40 Bearing 50×55×40	2	
6	36600072010	LGG045SP300H-04	间隔套 Spacer	2	高度≥4000用
7	56194010701	EKM	O形圈50X3 O-ring 50×3	2	高度<4000时无
8	36600041620	LGG045SP300H-03	活塞杆 Piston rod	2	
9	51466360119	GB/T895.1	挡圈42 Snap ring 42	2	
10	36600021140	LGG045SP300H-05	活塞 Piston	2	
11	56199009101		支承环65X70X20 Support ring 65×70×20	2	
12	56192015601		挡圈60X70X3 Snap ring 60×70×3	2	
13	56191001001		活塞密封圈70X60X7 Piston seal ring 70×60×7	2	
14	36600015351	LGG045SP300B-H.01	缸体 Cylinder body	2	
15	36600330010	LGG035SP300RH-07	滑阀 Spool	2	
16	36600191010	LGG035SP300RH-08	弹簧 Spring	2	
17	51515132002	GB/T119.1	圆柱销10X40 Cylindrical pin 10×40	2	
18	30082135101	LG0030D.10-009	轴套 Sleeve	2	
19	51207115314	GB/T5786	螺栓M12X1. 25X35 Bolt M12×1.25×35	2	
20	51401110107	GB/T93	垫圈12 Washer 12	2	
21	30086109601	LG0045D.10-007	卡箍 Clamp	2	
22	30082185000	LG0030D.10-012	箍座 Clamp seat	2	
23	30082113900	LG0030D.10-013	橡胶垫 Rubber pad	2	
24	51309000319	GB/T6171	螺母10X1. 25 Nut M10×1.25	4	
25	51401100107	GB/T93	垫圈10 Washer 10	4	
26	51421100115	GB/97.1	垫圈10 Washer 10	4	
27	51309000519	GB/T6171	螺母12X1. 25 Nut M12×1.25	2	
28	51207115614	GB/T5786	螺栓M12X1. 25X50 Bolt M12×1.25×50	2	
29	30086154800	LG0045DT.10-003	调整垫 Adjusting gasket	2	0.5mm
	30086154812	LG0045DT.10-003	调整垫 Adjusting gasket	2	1.0mm
	30086154813	LG0045DT.10-003	调整垫 Adjusting gasket	2	2.0mm
30	51204151814	GB/T5783	螺栓M20X60 Bolt M20×60	2	
31	51401150107	GB/T93	垫圈20 Washer 20	2	

倾斜油缸总成/Tilt cylinder assembly

通用

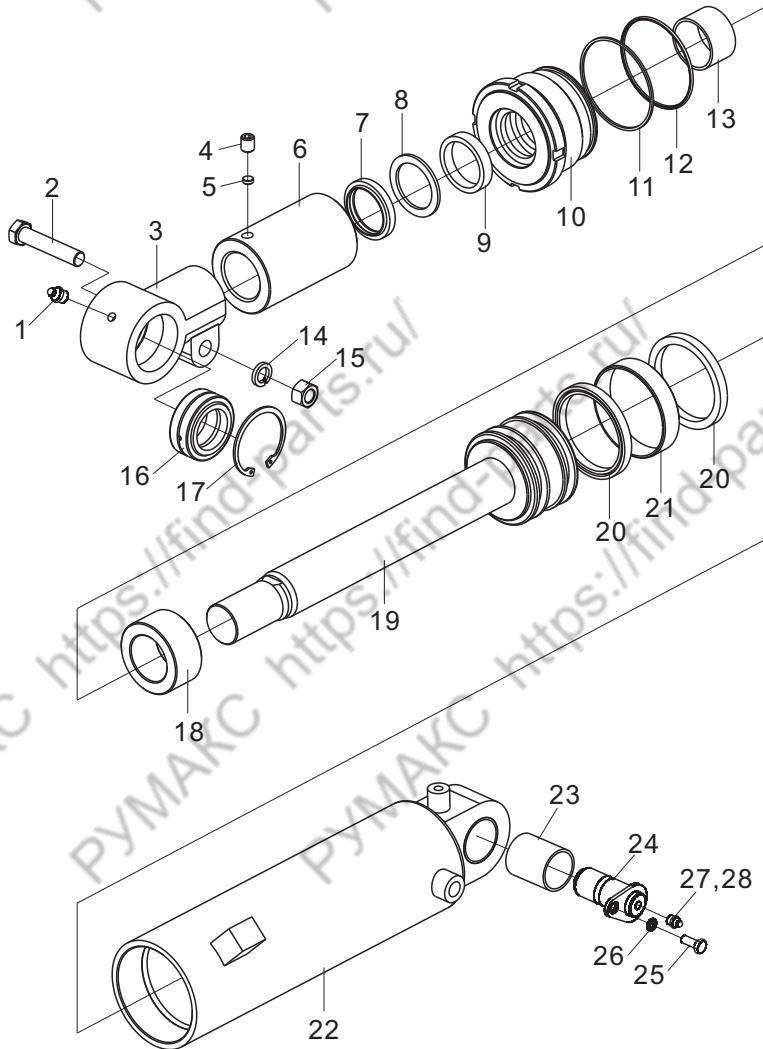

倾斜油缸参数/Tilt cylinder Parameter

左缸 Left cylinder	右缸 Right cylinder	前/后倾角 Tilt angle	限位套 Limited spacer	间隔套 Spacer	备注 Remark
16600040100	16600040130	6°-12°	—	—	
16600040110	16600040140	6°-6°	36600073090	—	
16600040120	16600040150	3°-6°	36600073090	36600071160	
16600040180	16600040190	3°-3°	36600071420	36600071160	

倾斜油缸总成/Tilt cylinder assembly

序号 Item No	编 码 Code	图 号 Part No	零 部 件 名 称 Description	数 量 Q'ty	备 注 Remark
A	16600040100	LG0045D.10.19	4. 5T左倾斜油缸6° /12° Left tilt cylinder	1	
B	16600040130	LG0045D.10.20	4. 5T右倾斜油缸6° /12° Right tilt cylinder	1	
1	56201000501	JB/T7940.1	油杯PT1/8 Fitting grease	2	
2	51210120114	GB/T5785	螺栓M14X1. 5X70 Bolt M14×1.5×70	2	
3	36600241080	LGG045X6/12H-01	杆头 Rod head	2	
4	51106221707	GB/T77	螺钉M10X12 Screw M10×12	2	
5	36600321020	LGG030X6/12H-02	锁紧垫 φ8X3 Locking Gasket	2	6°/12°无
6	36600073090	LGG045X6/6H-02	限位套 Limited spacer	2	6°/12°无
7	56193001701		防尘圈45X57X7 Dustproof ring	2	
8	56192015201		挡圈45X60X3 Snap ring 45×60×3	2	
9	56187019801		轴用密封圈45X60X11 Seal ring 45×60×11	2	
10	36600031110	LGG045X6/12H-03	导向套 Guide sleeve	2	
11	56192016101		挡圈85. 4X90X2 Snap ring 85.4×90×2	2	
12	56909000101	JISB2402	O形圈84. 4X3. 1 O-ring 84.4×3.1	2	
13	52500002801		钢背轴承45X50X30 Bearing	2	
14	51401120107	GB/T93	垫圈14 Washer 14	2	
15	51309000619	GB/T6171	螺母M14X1. 5 Nut M14×1.5	2	
16	52126000101	GB/T9163	关节轴承GE40ES Joint bearing	2	
17	51452460107	GB/T893.2	挡圈62 Snap ring 62	2	
18	36600071160	LGG045X6/12H-04	间隔套 Spacer	2	
19	36600042060	LGG045X6/12H.02	活塞杆组件 Piston rod element	2	
20	56191002901		活塞密封圈90X75X10 Piston seal ring 90×75×10	4	
21	56199009201		支承环85X90X20 Pivot ring 85×90×20	2	
22A	36600017802	LGG045X6/12LH.01	左缸体 Left cylinder	1	
22B	36600017812	LGG045X6/12RH.01	右缸体 Right cylinder	1	
23	52500002901		钢背轴承40X44X45 Bearing	2	
24	30086025001	LG0045DT.10.07	销轴焊合 Pin shaft weldment	2	
25	51204101114	GB/T5783	螺栓M10X25 Bolt M10×25	2	
26	51401100107	GB/T93	垫圈10 Washer 10	2	
27	56201000301	JB/T7940.1	油杯M10X1 Oil cup	2	
28	60980005823	LG0030D.10-021	红色保护套 Red sheath	2	

门架侧移管路(基本型) / Side shifting pipe mast(normal mast)

通用

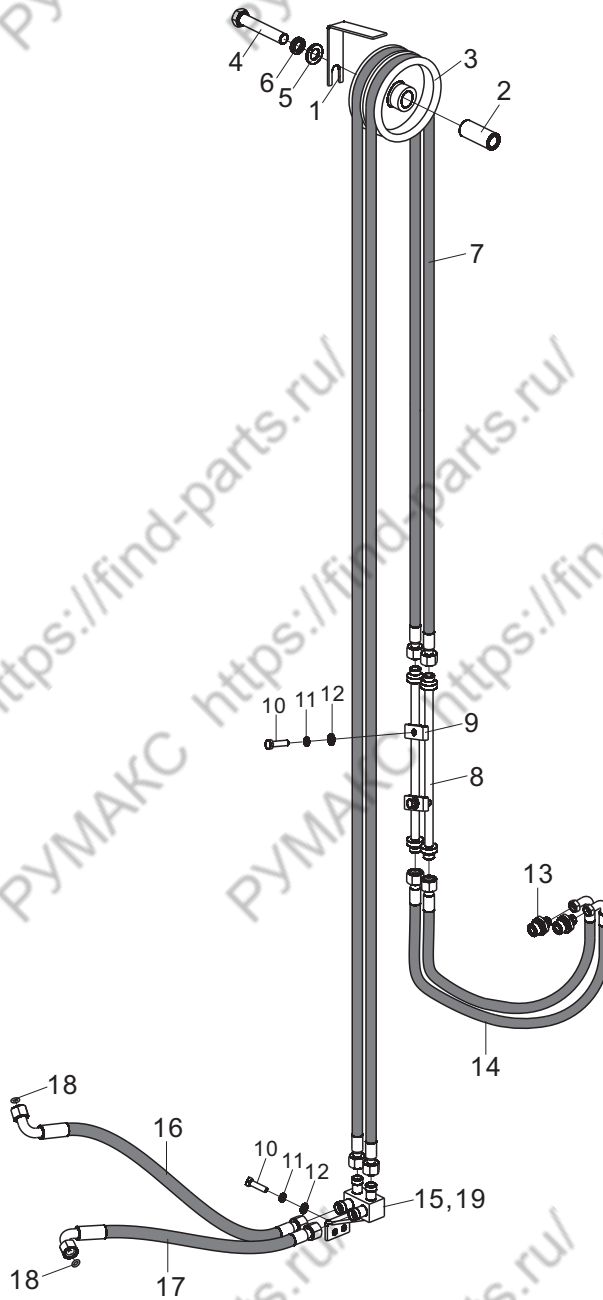

高度 Lifting height	2500	3000	3300	3500	3750	4000	4250
序号7胶管 Hose, NO.7	17272010168	17272009174	17272008636	17272008637	17272009179	17272008641	17272010169
高度 Lifting height	4500	4750	5000	5500	6000		
序号7胶管 Hose, NO.7	17272008643	17272010170	17272010171	17272010172	17272010173		

门架侧移管路(基本型) / Side shifting pipe mast(normal mast)

序号 Item No	编 码 Code	图 号 Part No	零部件名称 Description		数量 Q'ty	备 注 Remark
1	30086123004	LG0045D.10.21-001	挡板	Safeguard	1	四联2件
2	30086186504	LG0045D.10.21-002	套筒	Bushing	1	四联2件
3	30082185208	LG0030D.10B.11-002	滑轮	Pulley	2	四联4件
4	51210132414	GB/T5785	螺栓M16X1.5X90	Bolt M16×1.5×90	1	四联2件
5	51421130115	GB/T97.1	垫圈16	Washer 16	1	四联2件
6	51401130107	GB/T93	垫圈16	Washer 16	1	四联2件
7	17272009174	LG0045D.10.21.01	胶管总成	Hose assembly	2	四联4件
8	30082013300	LG0030D.10.13.02	钢管总成	Steel tube assembly	2	四联4件
9	30082107608	LG0030D.10.13-001	固定板	Fixed plate	2	四联4件
10	51204091214	GB/T5783	螺栓M8X30	Bolt M8×30	4	四联8件
11	51401090107	GB/T93	垫圈8	Washer 8	4	四联8件
12	51421090115	GB/T97.1	垫圈8	Washer 8	4	四联8件
13	17601000226	LG0060DT.10.11-001	过渡接头	Transition connector	2	四联4件
14	17272005538	LG0025D.10.08.13	胶管总成	Hose assembly	2	四联4件
15	30086071700	LG0045D.10.21.02	接头焊合	Connector weldment	1	三联用
16	17272005350	LG0025D.10.08.03	胶管总成	Hose assembly	1	四联2件
17	17272008103	LG0025D.10.08.12	胶管总成	Hose assembly	1	四联2件
18	56145077501	GB/T3452.1	O形圈8X2.65	O-ring 8×2.65	2	四联4件
19	30086071701	LG0045D.10.21.03	接头焊合	Connector weldment	1	四联用

门架起升管路(基本型) / Lift pipe mast (normal mast)

通用

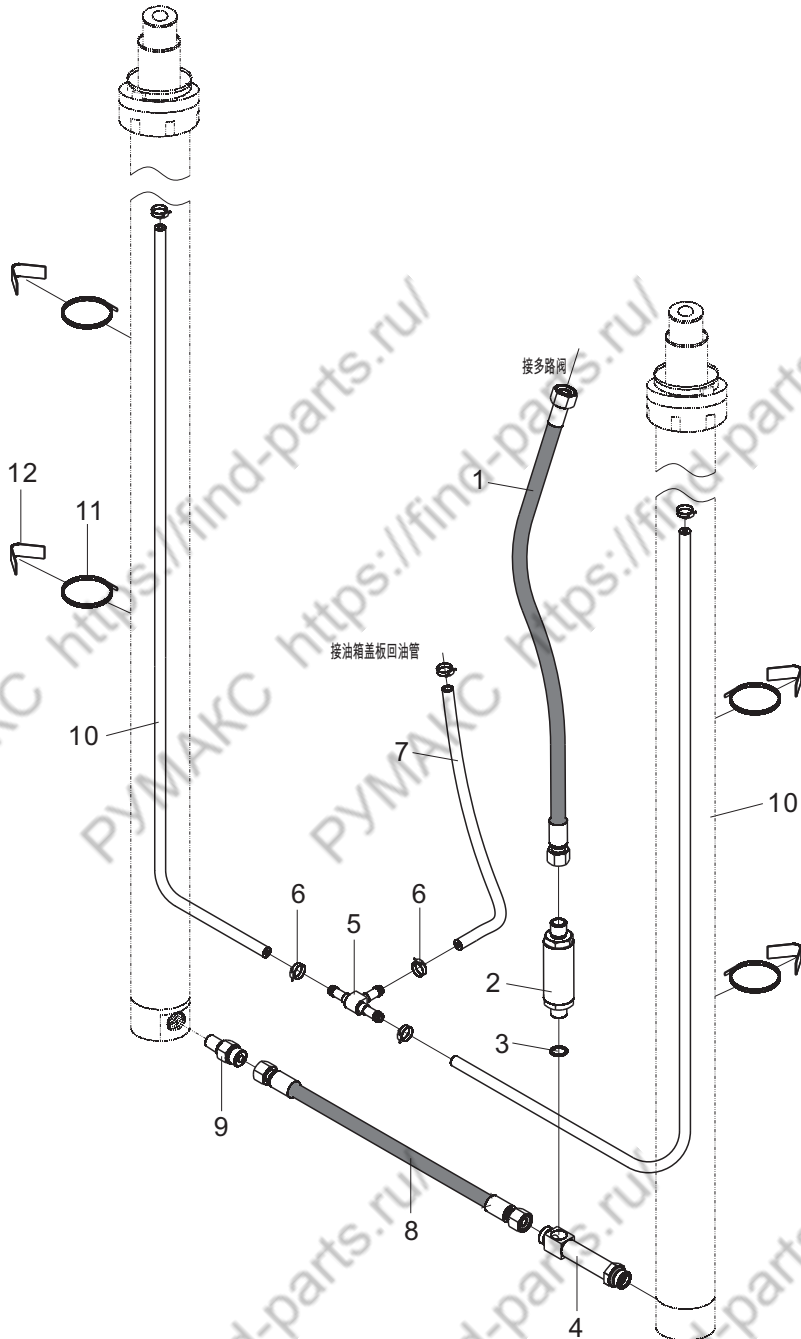

多路阀操纵 / Multi-way valve control

通用

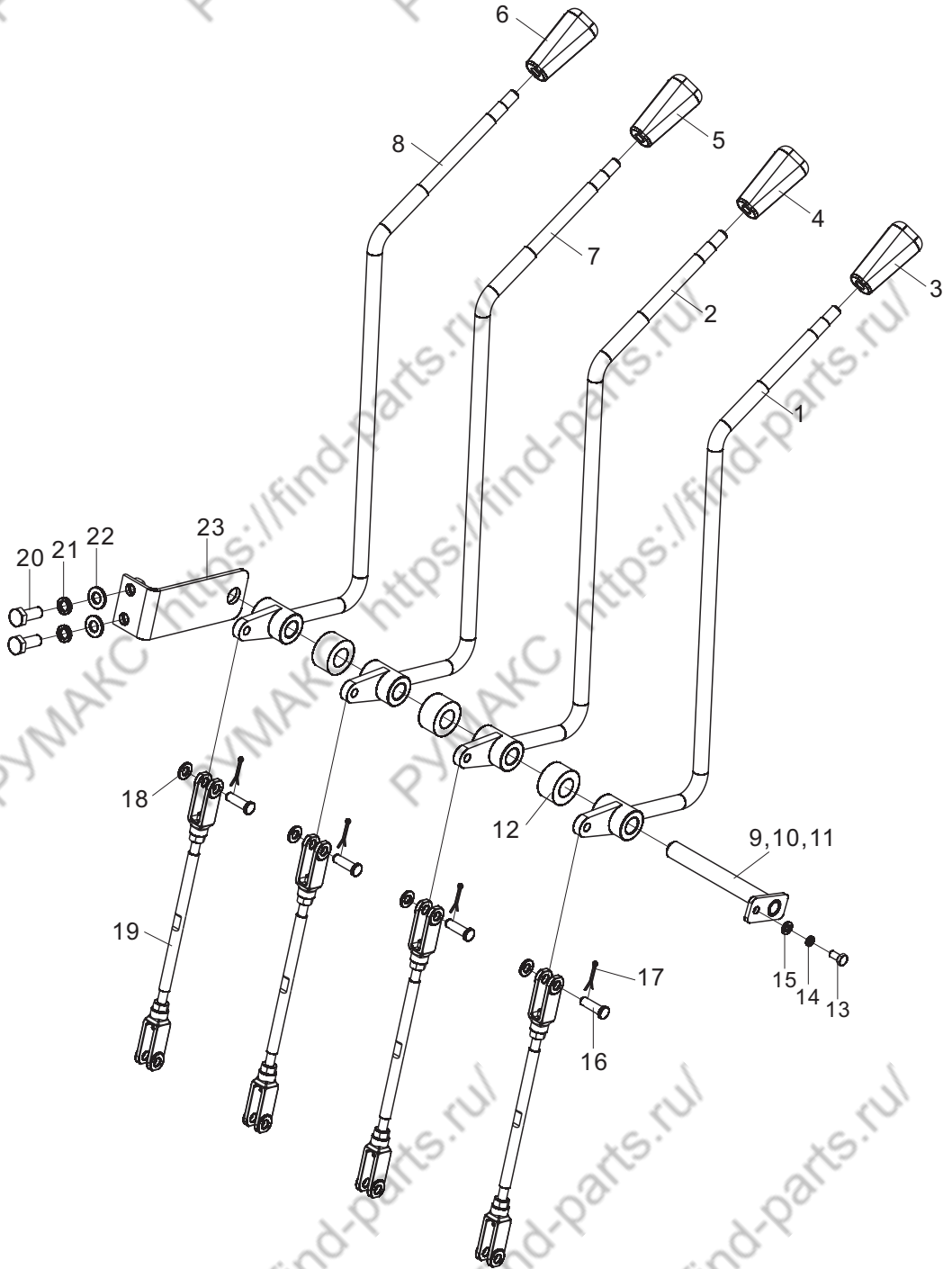

多路阀操纵/Multi-way valve control

序号 Item No	编 码 Code	图 号 Part No	零 部 件 名 称 Description	数 量 Q'ty	备 注 Remark
1	30011020624	LG0060DT.11.03	操纵杆焊合 Rod weldment	1	
2	30011020625	LG0060DT.11.04	操纵杆焊合 Rod weldment	1	
3	60207010081	LG0030D.11-002	手柄总成 Handle assembly	1	
4	60207010080	LG0030D.11-001	手柄总成 Handle assembly	1	
5	60207010082	LG0030D.11-003	手柄总成 Handle assembly	0	三联1件/四联1件
6	60207010083	LG0030D.11-004	手柄总成 Handle assembly	0	四联1件
7	30011020626	LG0060DT.11.10	操纵杆焊合 Rod weldment	0	三联1件/四联1件
8	30011020627	LG0060DT.11.11	操纵杆焊合 Rod weldment	0	四联1件
9	30011025005	30D-1131100	销轴焊合 Shaft weldment	1	二联1件
10	30011025018	LG0060DT.11.12	销轴焊合 Shaft weldment	0	三联1件
11	30011025019	LG0060DT.11.13	销轴焊合 Shaft weldment	0	四联1件
12	30011106403	LG0060DT.11-001	垫圈 Washer	3	三联4件/四联5件
13	51204080814	GB/T5783	螺栓M6X12 Bolt M6×12	1	
14	51401080107	GB/T93	垫圈6 Washer 6	1	
15	51421080115	GB/T97.1	垫圈6 Washer 6	1	
16	51511051102	GB/T882	销B8X26 Pin 8×26	4	三联6件/四联8件
17	51512071001	GB/T91	销2.5X20 Pin 2.5×20	4	三联6件/四联8件
18	51421090115	GB/T97.1	垫圈8 Washer 8	4	三联6件/四联8件
19	30011023000	LG0045DT.11.02	连接杆总成 Connecting rod	2	三联3件/四联4件
20	51204101114	GB/T5783	螺栓M10X25 Bolt M10×25	2	
21	51401100107	GB/T93	垫圈10 Washer 10	2	
22	51421100115	GB/T97.1	垫圈10 Washer 10	2	
23	30011040101	LG0045DT.11.01	固定板焊合 Fixed plate	1	

液压系统/Hydraulic system

通用

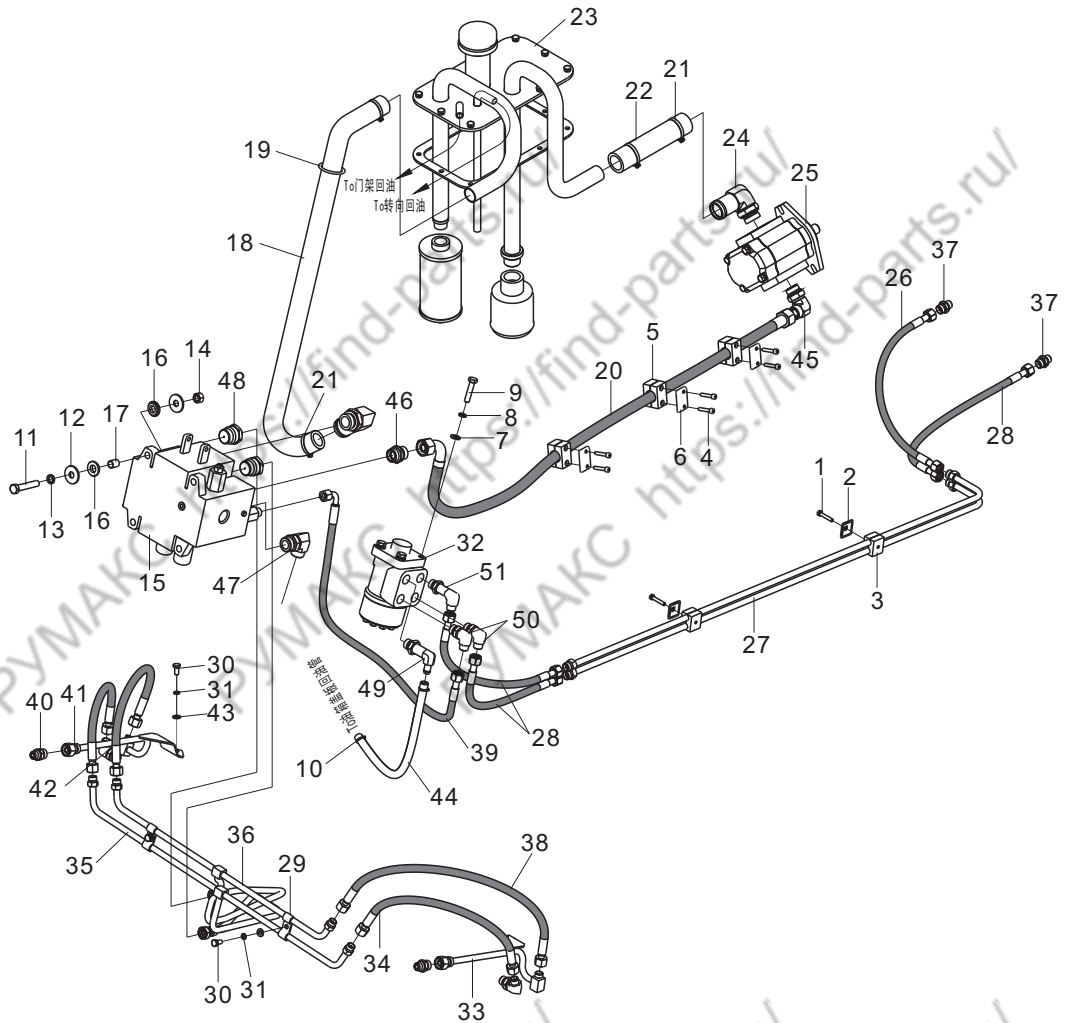

液压系统/Hydraulic system

序号 Item No	编 码 Code	图 号 Part No	零部件名称 Description	数量 Q'ty	备 注 Remark	
1	51203081314	GB/T5782	螺栓M6X35	Bolt M6×35	2	
2	30012107904	LG0045DXAIII.12-012	管夹盖板	Clip cover plate	2	
3	30012014000	LG0045DXAIII.12.10	管夹总成	Clip assembly	2	
4	51204081414	GB/T5783	螺栓M6X40	Bolt M6×40	6	
5	60911013461	LG0160DT.08.05	管夹	Clip	3	
6	60911013462	LG0160DT.08-007	盖板	Cover plate	3	
7	51421100115	GB/T97.1	垫圈10	Washer 10	4	
8	51401100107	GB/T93	垫圈10	Washer 10	4	
9	51204101514	GB/T5783	螺栓M10X45	Bolt M10×45	4	
10	56171002301	JB/T8870	喉箍d25(16~25)	Hoop d25(16~25)	2	
11	51204111914	GB/T5783	螺栓M12X65	Bolt M12×65	4	
12	51420110121	GB/T96.1	垫圈12	Washer 12	8	
13	51401110107	GB/T93	垫圈12	Washer 12	4	
14	51307001119	GB/T6170	螺母M12	Nut M12	4	
15	60304000548	LG0045D.12.07	多路阀	Multi-way valve	1	两片
	60304000680	LG0045D.12.10	多路阀	Multi-way valve	1	三片
	60304000681	LG0045D.12.11	多路阀	Multi-way valve	1	四片
16	30012113906	LG0060DT.12-031	橡胶垫	Rubber gasket	8	
17	30012122301	LG0045DXAIII.12-005	衬套	Bushing	4	
18	30012106005	LG0045DXAIII.12-006	成型管	Molding pipe	1	
19	68080000005	LG0100DT.12-020	扎带8X350	Binding tape 8×350	2	
20	17272010632	LG0045DXAIII.12-007	胶管总成	Hose assembly	1	
21	56171000601	JB/T8870	喉箍d50(32~50)	Hoop d50(32~50)	4	
22	30012106006	LG0045DXAIII.12-008	成型管	Molding pipe	1	
23	30012073012	LG0045DXAIII.12.02	液压油箱盖板总成	Cover plate assembly	1	
24	17601001614	LG0045DT.12.53	过渡接头	Transition connector	1	
25	60300000262	LG0045DXAIII.12.03	齿轮泵	Gear pump	1	
26	17272010633	LG0045DXAIII.12-009	胶管总成	Hose assembly	1	
27	30012013053	LG0045DXAIII.12.04	钢管总成	Hose assembly	2	
28	17272010634	LG0045DXAIII.12-010	胶管总成	Hose assembly	3	
29	30012107818	LG0060DT.12-008	管夹	Clip	2	
30	51204090914	GB/T5783	螺栓M8X16	Bolt M8×16	4	
31	51401090107	GB/T93	垫圈8	Washer 8	4	
32	60305000014	LG0045DXAIII.12.06	转向器	Steering gear	1	
33	30012013304	LG0045DT.12.47	钢管总成	Steel tube assembly	1	
34	17272010635	LG0045DXAIII.12-011	胶管总成	Steel tube assembly	2	

液压系统/Hydraulic system

序号 Item No	编 码 Code	图 号 Part No	零 部 件 名 称 Description	数 量 Q'ty	备 注 Remark
35	30012013055	LG0045DXAIII.12.07	钢管总成 Steel tube assembly	1	
36	30012013054	LG0045DXAIII.12.05	钢管总成 Steel tube assembly	1	
37	30012108306	LG0045DT.12-045	过渡接头 Transition connector	2	
38	17272006791	LG0045DT.12-056	胶管总成 Hose assembly	2	
39	17272010631	LG0045DXAIII.12-004	胶管总成 Hose assembly	1	
40	17601000454	LG0060DT.12-025	过渡接头 Transition connector	2	
41	30012013303	LG0045DT.12.40	钢管总成 Steel tube assembly	1	
42	30012008300	LG0045DT.12.41	过渡接头 Transition connector	2	
43	51421090115	GB/T97.1	垫圈8 Washer 8	4	
44	30012187935	LG0040D.12.06-002	回油管 Oil rreturn pipe	1	
45	30012008305	LG0045DXAIII.12.08	过渡接头 Transition connector	1	
46	17601000156	LG0045D.12-013	过渡接头 Transition connector	1	
47	30012008302	LG0045DT.12.52	过渡接头 Transition connector	1	
48	17601000226	LG0060DT.10.11-001	过渡接头 Transition connector	2	
49	30012008308	LG0045DXAIII.12.09	过渡接头 Transition connector	1	
50	30012008303	LG0045DT.12.54	过渡接头 Transition connector	2	
51	30012008304	LG0045DT.12.55	过渡接头 Transition connector	1	

液压油箱盖板总成 / Hydraulic oil tank cover plate

通用

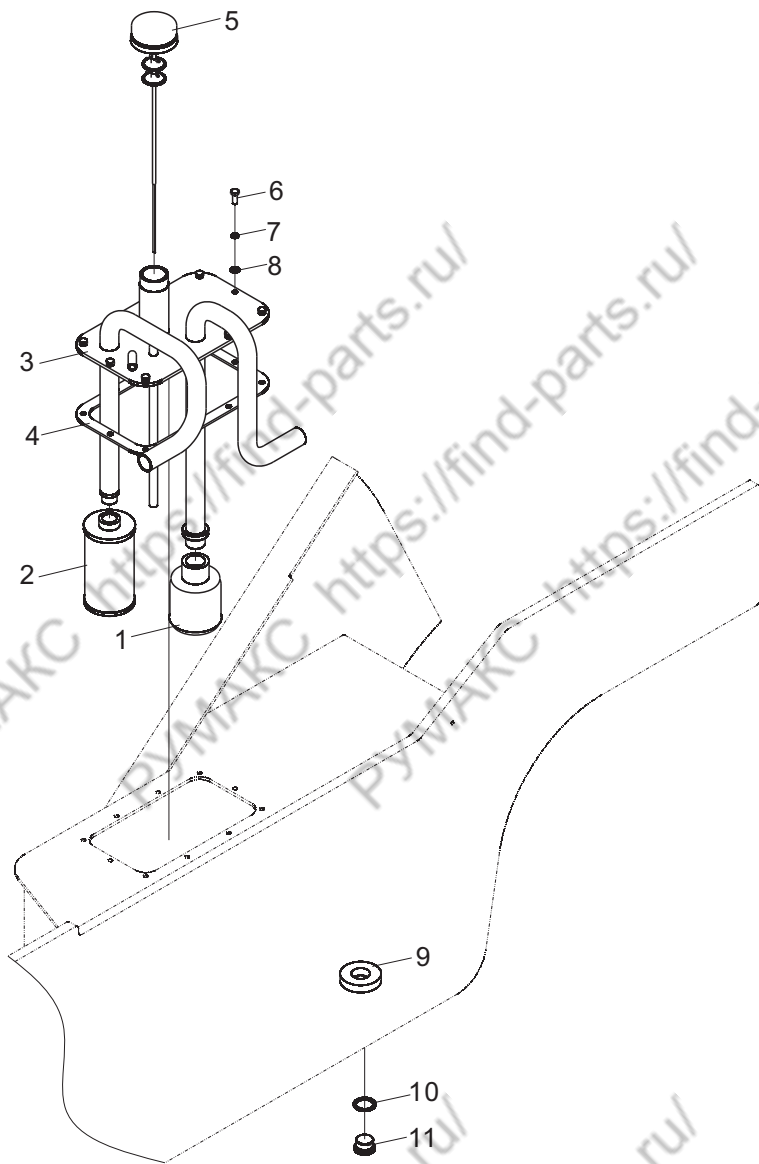

护顶架/Overhead guard

通用

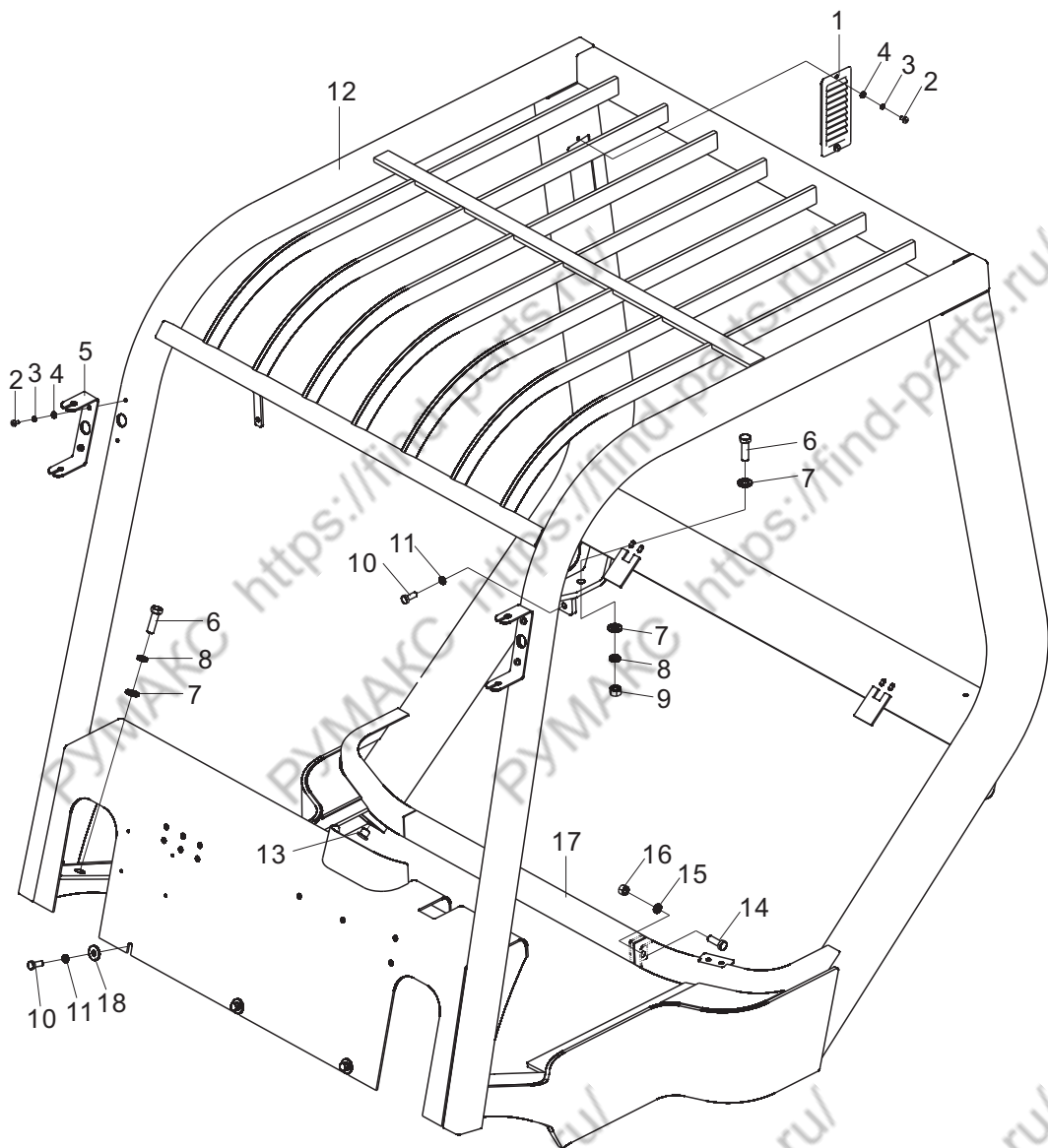

电气系统/ Electric system

通用

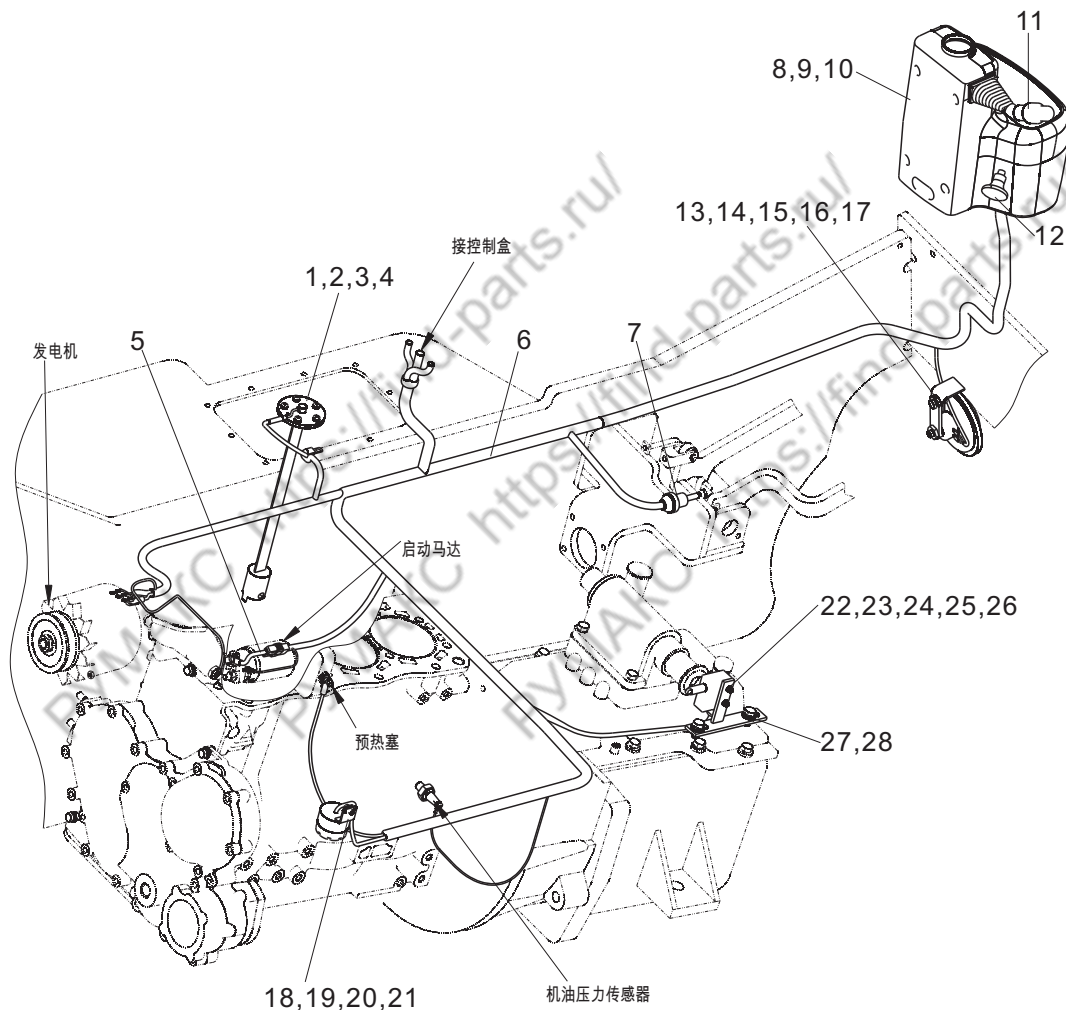

电气系统/Electric system

序号 Item No	编 码 Code	图 号 Part No	零部件名称 Description	数量 Q'ty	备 注 Remark
1	30015163611	LG0045DXAIII.15-001	油量传感器 Oil capacity sensor	1	
2	51158170404	GB/T818	螺钉M5X12 Screw M5×12	5	
3	51401070107	GB/T93	垫圈5 Washer 5	5	
4	51421070115	GB/T97.1	垫圈5 Washer 5	5	
5	30015068302	LG0030DIII.15.09	易熔线 Fusible wire	1	
6	30015067617	LG0045DXAIII.15.03	线束总成 Wiring harness assembly	1	
7	60405020218	LG0030D.15-006	刹车灯开关 Brake lamp switch	1	
8	30015163419	LG0060DT.15.18	组合仪表 Combination instrument	1	
9	51204081214	GB/T5783	螺栓M6X30 Bolt M6×30	4	
10	51430080114	GB/T5287	垫圈6 Washer 6	4	
11	60405020047	LG0030D.15-003	组合开关 Combination switch	1	
12	60405020128	LG0030D.15-005	警示灯开关 Warning lamp	1	选配
13	60401050090	LG0060DT.15-005	喇叭 Horn	1	
14	51421090115	GB/T97.1	垫圈8 Washer 8	1	
15	51401090107	GB/T93	垫圈8 Washer 8	1	
16	51204090914	GB/T5783	螺栓M8X16 Bolt M8×30	1	
17	51307000919	GB/T6170	螺母M8 Nut M8	1	
18	51204080814	GB/T5783	螺栓M6X12 Bolt M6×12	1	
19	51401080107	GB/T93	垫圈6 Washer 6	1	
20	51421080115	GB/T97.1	垫圈6 Washer 6	1	
21	60401050091	LG0060DT.15-011	倒车蜂鸣器 Backup buzzer	1	
22	30015162310	LG0045DXAIII.15.07	微动开关 Inching switch	1	
23	51158141104	GB/T818	螺钉M4X35 Screw M4×35	2	
24	51421060115	GB/T97.1	垫圈4 Washer 4	2	
25	51401060107	GB/T93	垫圈4 Washer 4	2	
26	51307000619	GB/T6170	螺母M4 Nut M4	2	
27	30015018101	LG0045DXAIII.15.06	支架焊合 Bracket weldment	1	
28	51421100115	GB/T97.1	垫圈10 Washer 10	2	

护顶架线束总成/Overhead guard harness assembly

通用

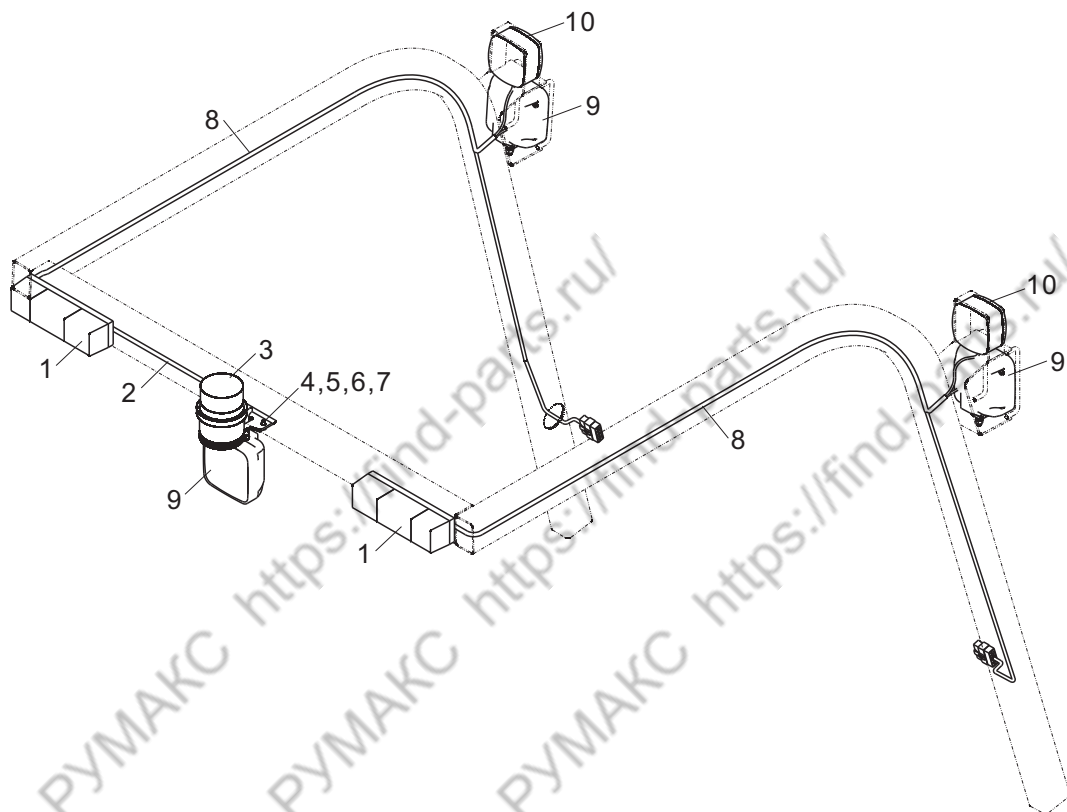

序号 Item No	编 码 Code	图 号 Part No	零 部 件 名 称 Description	数 量 Q'ty	备 注 Remark
1	30015064409	LG0045DXAIII.15.04	后组合灯 Rear combination lamp	2	
2	30015061317	LG0045DXAIII.15.02	灯具线束 Lamp harness	1	选配
3	30015064403	LG0030B.15.19	警示灯 Warning lamp	1	选配
4	30008133529	LG0030DTIHIII.15-001	支板 Support plate	1	选配
5	51204080914	GB/T5783	螺栓M6X16 Bolt M6×16	2	选配
6	51401080107	GB/T93	垫圈6 Washer 6	2	选配
7	51421080115	GB/T97.1	垫圈6 Washer 6	2	选配
8	30015061316	LG0045DXAIII.15.01	灯具线束 Lamp harness	2	
9	30015064202	LG0045DT.15.01	工作灯 Working lamp	2	选配(后照灯时为3)
10	30015067102	LG0060DT.15.02	前组合灯 Front combination lamp	2	

蓄电池总成/Battery assembly

通用

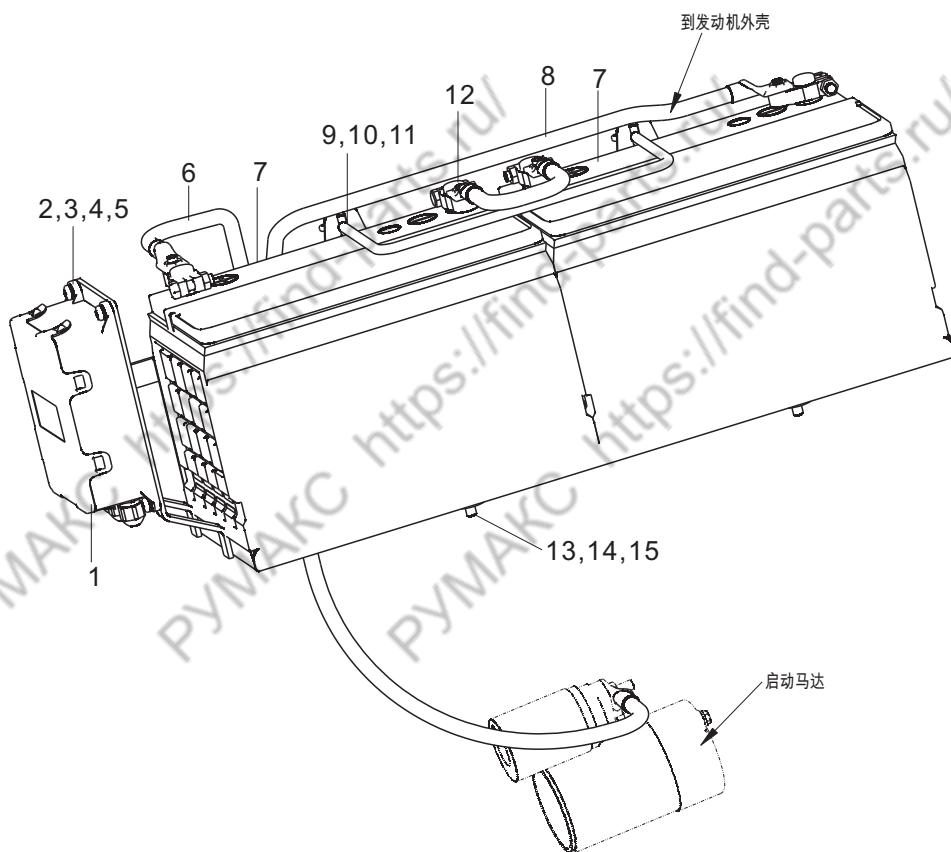

蓄电池总成/Battery assembly

序号 Item No	编 码 Code	图 号 Part No	零 部 件 名 称 Description		数量 Q'ty	备 注 Remark
1	30015069103	LG0045DT.15.12	控制盒	Control box	1	
2	51158190304	GB/T818	螺钉M6x12	Screw M6×12	4	
3	51421080115	GB/T97.1	垫圈6	Washer 6	4	
4	30015062104	LG0045DT.15.09.01	电瓶支架焊合	Battery bracket weldment	1	
5	30015156800	30D-1541001	隔热垫	Heat insulation gasket	2	
6	30015066207	LG0045DT.15.10	连接电缆	Connecting cable	1	
7	60401030028	LG0030D.15.05.01	蓄电池	Battery	2	
8	30015061502	LG0045DT.15.08	地线电缆	Ground cable	1	
9	30015161301	LG0045DT.15.09-001	卡子	Clip	1	
10	51420080121	GB/T96.1	垫圈6	Washer 6	2	
11	51354000404	GB/T62.1	螺母M6	Nut M6	2	
12	30015066206	LG0045DT.15.07	连接电缆	Connecting cable	1	
13	51204090914	GB/T5783	螺栓M8x16	Bolt M8×16	4	
14	51421090115	GB/T97.1	垫圈8	Washer 8	4	
15	51401090107	GB/T93	垫圈8	Washer 8	4	

标牌/Label

LG45DXAIII、LG40DXAIII

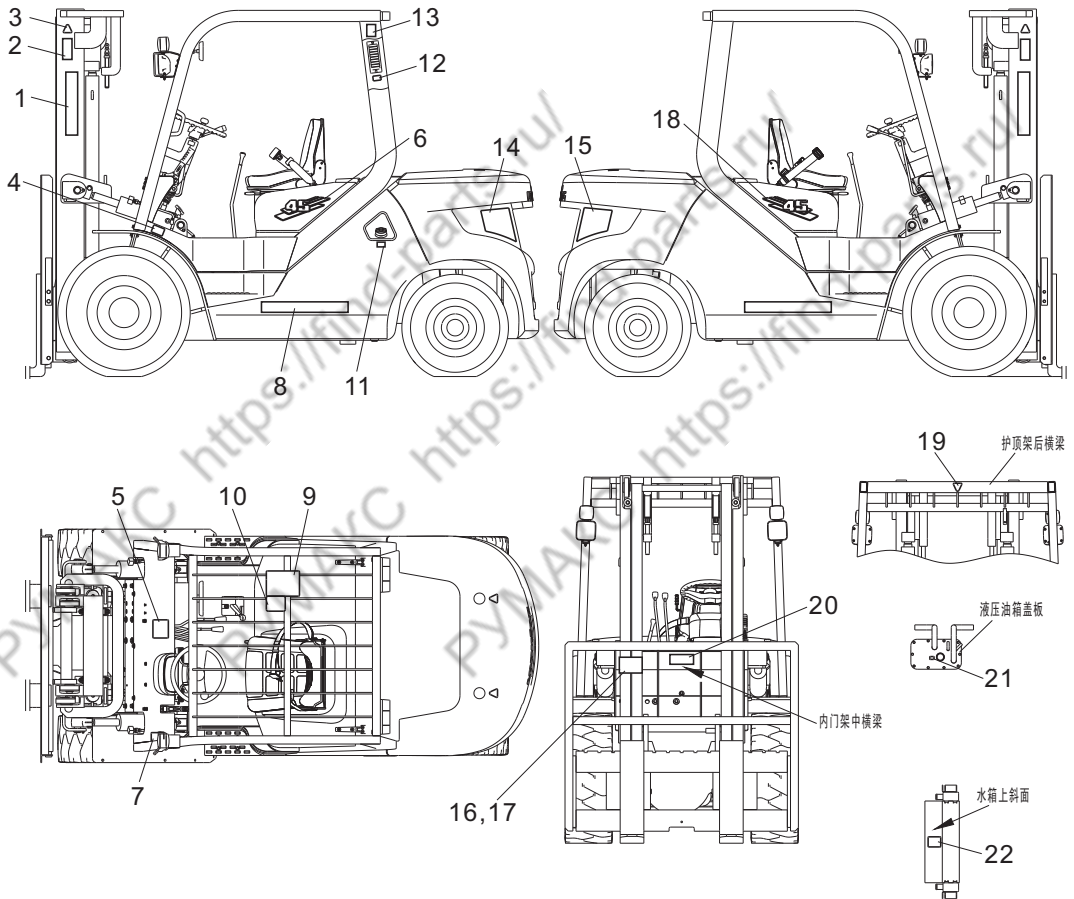

标牌/Label

序号 Item No	编 码 Code	图 号 Part No	零部件名称 Description	数量 Q'ty	备 注 Remark
1	30016197506	LG0030D.16-003	龙工标志 Lonking label	2	
2	30016197312	LG0030D.16-001	警示标牌货叉上下禁止停留 No stay on and under fork	2	
3	30016197802	LG0030D.16-002	起吊点标牌 Lift point label	4	
4	30016197610	LG0045DXAIII.16-001	轮胎气压标牌 Tire pressure label	1	
5	30016198620	LG0045D.16-002	载荷曲线图标牌 Load curve chart label	1	
6	30016198270	LG0045DXAIII.16-002	型号标牌 Model label	1	45DXAIII
	30016198272	LG0040DXAIII.16-001	型号标牌 Model label	1	40DXAIII
7	80380801888	LG0030D.16-033	防冻液标签-35℃ Antifreeze fluid label-35℃	1	
8	30016197514	LG0045DXAIII.16-008	龙工标志 Lonking label	2	
9	30016197902	LG0030D.16-010	润滑点标牌 Lubrication point label	1	
10	30016198001	LG0030D.16-011	说明标牌(中文) Operation label(Chinese)	1	
11	30016198503	LG0030D.16-006	油品标牌 Oil label	1	
12	30016197314	LG0030D.16-018	警示标牌严禁冲水 Warning label-no flushing	1	
13	30016197101	LG0030D.16-005	叉车吊运标牌 Lifting and transporting label	1	
14	30016199102	LG0045DXAIII.16-004	反光贴 Reflective sticker	1	
15	30016199103	LG0045DXAIII.16-005	反光贴 Reflective sticker	1	
16	30016197701	LG0030D.16-015	铭牌 Nameplate	1	
17	51569000106	GB/T12618.1	抽芯铆钉4X12 Mandrel blind rivet 4×12	4	
18	30016198271	LG0045DXAIII.16-007	型号标牌 Model label	1	45DXAIII
	30016198273	LG0045DXAIII.16-002	型号标牌 Model label	1	40DXAIII
19	30016197315	LG0030D.16-019	警示标牌禁止起吊 Do not lift	1	
20	30016197313	LG0030D.16-017	警示标牌勿伤手 Do not hurt the hand	1	
21	30016198504	LG0030D.16-009	油品标牌 Oil label	1	
22	30016197316	LG0100DT.16-013	警示标牌勿伤手指 Do not hurt the finger	1	

平衡重/Counter weight

LG45DXAIII、LG40DXAIII

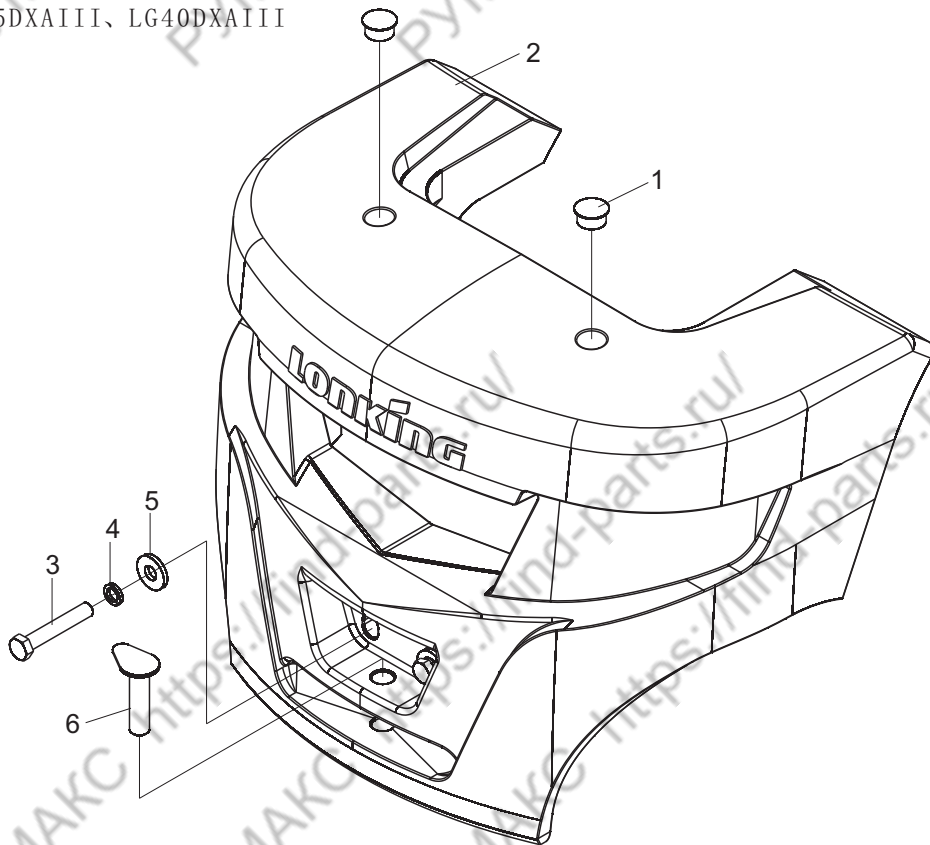

序号 Item No	编 码 Code	图 号 Part No	零部件名称 Description	数量 Q'ty	备 注 Remark
1	30017159100	30D-1700002	孔塞 Orifice plug	2	
2	30017151602	LG0045DXAIII.17-001	平衡重 Counter weight	1	45DXAIII
	30017151604	LG0040DXAIII.17-001	平衡重 Counter weight	1	40DXAIII
3	51210193414	GB/T5785	螺栓M30X2X180 Bolt M30×2×180	2	
4	51401200107	GB/T93	垫圈30 Washer 30	2	
5	30017106400	LG0030D.17-003	垫圈 Washer	2	
6	30017038509	LG0045DXAIII.17.01	牵引销焊合 Traction pin weldment	1	